

(12) INTERNATIONAL APPLICATION PUBLISHED UNDER THE PATENT COOPERATION TREATY (PCT)

(19) World Intellectual Property Organization  
International Bureau



(43) International Publication Date  
14 April 2005 (14.04.2005)

PCT

(10) International Publication Number  
WO 2005/033659 A2

- (51) International Patent Classification: G01N [US/US]; 361 Tyrella Avenue, B, Mountain View, CA 94043 (US). LUM, Paul [US/US]; 690 Templebar Way, Los Altos, CA 94022 (US). ALDEN, Don [US/US]; 1312 Nelson Way, Sunnyvale, CA 94087 (US). ROSS, James [US/US]; 869 Lucerne Street, Livermore, CA 94551 (US). BARDELL, Ron, L. [US/US]; 4150 Alabama Ave S, St. Louis Park, MN 55416 (US). WEIGLE, Bernhard [US/US]; 5530 Canfield Place N, Seattle, WA 98103 (US).
- (21) International Application Number: PCT/US2004/032025
- (22) International Filing Date: 29 September 2004 (29.09.2004)
- (25) Filing Language: English
- (26) Publication Language: English
- (27) Agent: TUNG, Hao, Y.; Heller Ehrman White & McAuliffe LLP, 275 Middlefield Road, Menlo Park, CA 94025-3506 (US).
- (30) Priority Data:  
60/507,317 29 September 2003 (29.09.2003) US  
60/507,852 30 September 2003 (30.09.2003) US  
60/507,845 30 September 2003 (30.09.2003) US  
60/507,690 30 September 2003 (30.09.2003) US  
60/507,688 30 September 2003 (30.09.2003) US
- (81) Designated States (unless otherwise indicated, for every kind of national protection available): AE, AG, AL, AM, AT, AU, AZ, BA, BB, BG, BR, BW, BY, BZ, CA, CH, CN, CO, CR, CU, CZ, DE, DK, DM, DZ, EC, EE, EG, ES, FI, GB, GD, GE, GH, GM, HR, HU, ID, IL, IN, IS, JP, KE, KG, KP, KR, KZ, LC, LK, LR, LS, LT, LU, LV, MA, MD, MG, MK, MN, MW, MX, MZ, NA, NI, NO, NZ, OM, PG, PH, PL, PT, RO, RU, SC, SD, SE, SG, SK, SL, SY, TJ, TM, TN, TR, TT, TZ, UA, UG, US, UZ, VC, VN, YU, ZA, ZM, ZW.
- (71) Applicant (for all designated States except US): PE-LIKAN TECHNOLOGIES, INC. [US/US]; 1072 East Meadow Circle, Palo Alto, CA 94303 (US).
- (72) Inventors; and
- (75) Inventors/Applicants (for US only): MARSOT, Travis
- (84) Designated States (unless otherwise indicated, for every kind of regional protection available): ARIPO (BW, GH,

[Continued on next page]

(54) Title: METHOD AND APPARATUS FOR AN IMPROVED SAMPLE CAPTURE DEVICE

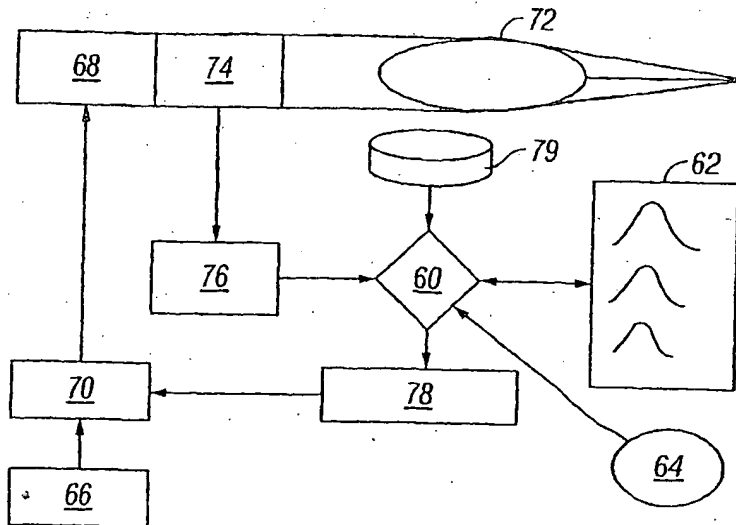

(57) Abstract: A body fluid sampling device is provided. A mesh may be used to guide blood or fluid to travel directly from the wound to an analyte detecting port on the cartridge. Thus the volume of blood or body fluid produced at the wound site regardless of its droplet geometry can be reliable and substantially completely transported to the analyte detecting member for measurement.

WO 2005/033659 A2



GM, KE, LS, MW, MZ, NA, SD, SL, SZ, TZ, UG, ZM, ZW), Eurasian (AM, AZ, BY, KG, KZ, MD, RU, TJ, TM), European (AT, BE, BG, CH, CY, CZ, DE, DK, EE, ES, FI, FR, GB, GR, HU, IE, IT, LU, MC, NL, PL, PT, RO, SE, SI, SK, TR), OAPI (BF, BJ, CF, CG, CI, CM, GA, GN, GQ, GW, ML, MR, NE, SN, TD, TG).

**Published:**

— without international search report and to be republished upon receipt of that report

*For two-letter codes and other abbreviations, refer to the "Guidance Notes on Codes and Abbreviations" appearing at the beginning of each regular issue of the PCT Gazette.*

## METHOD AND APPARATUS FOR AN IMPROVED SAMPLE CAPTURE DEVICE

5

### BACKGROUND OF THE INVENTION

Lancing devices are known in the medical health-care products industry for piercing the skin to produce blood for analysis. Typically, a drop of blood for this type of analysis is obtained by making a small incision in the fingertip, creating a small wound,  
10 which generates a small blood droplet on the surface of the skin.

Early methods of lancing included piercing or slicing the skin with a needle or razor. Current methods utilize lancing devices that contain a multitude of spring, cam and mass actuators to drive the lancet. These include cantilever springs, diaphragms, coil springs, as well as gravity plumbs used to drive the lancet. The device may be held  
15 against the skin and mechanically triggered to ballistically launch the lancet. Unfortunately, the pain associated with each lancing event using known technology discourages patients from testing. In addition to vibratory stimulation of the skin as the driver impacts the end of a launcher stop, known spring based devices have the possibility of firing lancets that harmonically oscillate against the patient tissue, causing multiple  
20 strikes due to recoil. This recoil and multiple strikes of the lancet is one major impediment to patient compliance with a structured glucose monitoring regime.

When using existing methods, blood often flows from the cut blood vessels but is then trapped below the surface of the skin, forming a hematoma. In other instances, a wound is created, but no blood flows from the wound. In either case, the lancing process  
25 cannot be combined with the sample acquisition and testing step. Spontaneous blood droplet generation with current mechanical launching system varies between launcher types but on average it is about 50% of lancet strikes, which would be spontaneous. Otherwise milking is required to yield blood. Mechanical launchers are unlikely to provide the means for integrated sample acquisition and testing if one out of every two  
30 strikes does not yield a spontaneous blood sample. It would be desirable to find improved methods to actuate the lancet.

As lancing devices have become more advanced, so have the sensors used to measure the glucose levels in the blood samples. These analyte sensors now operate using increasing lower volumes of blood sample. Some of these analyte sensors are designed for use with lancing devices that create smaller wounds, which is beneficial in that there is less pain and tissue damage, but also provide less blood to work with. As the required amount of blood decreases, it becomes increasingly important to guide the ever shrinking volumes of blood towards the sensor in an efficient manner that does not waste the small volumes of blood. At low volumes, it is desirable to regulate fluid flow so that the small amounts of fluid are not wasted on surfaces that do not provide an analyte measurement.

A still further problem concerns the possible inability to guarantee blood flow from the finger lancet wound to the sensor port located on the disposable cartridge. The problem might be the invariability of the blood volume from the lancet wound, otherwise known as the shape and size of the droplet. There have been stated solutions such as the delivery of the lancet to the finger with a deeper penetration depth or a programmed controlled "lancet-in-the-finger" dwell time to sustain the size of the wound, which allows more blood to be produced from the wound. However, each might possibly result in a compromise on the degree of pain or sensation felt by the patient.

In some embodiments, a capillary may be co-located with the lancet. In order to get the blood into the capillary, several variables (lateral movement or other variation) come into play. Unless the blood droplet is directly centered on the capillary, there may be difficulty transporting enough blood to the analyte detecting member. For example, if there is any type of lateral movement or if the blood does not fall into the capillary tube, it can smear on the side wall. With an integrated sampling configuration where it may be difficult to visualize where the blood or body fluid is going, there may be no way for the subject to rectify the situation by milking the finger to get a larger droplet and increase the potential of getting the blood in.

The design of these improved medical devices has also challenged engineers to come up with more efficient methods of design. With macroscopic devices, such as conventional blood chemistry analyzers or flow cytometers, it is usually possible during the development phase to mount flow sensors, temperature probes, and optical detectors at various positions along the instrument pathway to experimentally determine the

optimum operational parameters for the device. However, this approach often fails for microdevices because standard sensors and probes are typically of the same scale as the microdevice and interfere so much with device behavior that the measured data do not represent actual device performance. Thus it would be desirable to come up with design models where the most useful experimental data tend to be external measurements from which the internal physics of the microdevice should be deduced.

### SUMMARY OF THE INVENTION

The present invention provides solutions for at least some of the drawbacks discussed above. The technical field relates to guiding a fluid sample obtained from the body for analysis. Because of the low fluid volumes envisioned for improved sensing devices, the ability to efficiently guide the small sample volumes to a targeted area is of interest. Specifically, some embodiments of the present invention provide a body fluid sampling device with improved fluid control. Preferably, the improved fluid control is easy to use. At least some of these and other objectives described herein will be met by embodiments of the present invention.

In one aspect, the present invention provides surface texturing that corrals or guides fluid in areas that desire to receive the fluid sample. The texturing may also be used in combination with other surface treatments such as coatings. Texturing, however, it a more permanent solution.

In one embodiment, a radial cartridge is provided that has a plurality of penetrating members and a plurality of analyte detecting members where texturing near the detecting members guides the fluid to the members. The texturing may be formed by a variety of techniques as known in the art and can be formed in various geometries. The present invention allows very small volumes of fluid to be guided by restricting its flow due to surface texturing.

In another aspect of the present invention, the invention relates to using an electronic tissue penetration device to drive a penetrating member into tissue, sample the body fluid, and measure analyte levels in the body fluid using a sensor cartridge. The invention uses various techniques to draw body fluid towards an analyte detecting device on the cartridge.

Embodiments of the present invention provide solutions to a problem, which concerns the possible inability to guaranteed a stable blood volume from a finger lancet wound to a sensor port located on a disposable cartridge. The problem might be due to shallowness of the lancet penetration depth, skin surface tension issues, or the patient's vascular conditions resulting in the invariability in achieving an adequate blood droplet shape and size. There have been other stated solutions such as the delivery of the lancet to the finger with a deeper penetration depth or a control method to increase the amount of blood to be produced from the wound.

In one embodiment, this invention produces a concept of a capillary need for the blood to travel directly from the wound to the sensor port on the cartridge. Thus the volume of blood produced at the wound site irregardless of its droplet geometry can be completely transported to the analyte detecting member.

In a still further aspect, the present invention provides solutions for at least some of the drawbacks discussed above. Specifically, some embodiments of the present invention provide an improved, integrated fluid sampling device. To improve device integration, devices and methods for connecting sensor regions to contact pad regions may be provided. One of the problems involves getting electrical contact with the leads connected to electrodes coupled to the sensor regions. At least some of these and other objectives described herein will be met by embodiments of the present invention.

In yet another aspect, the technical field of the invention relates to thick film conductor depositions for the purpose of providing sensory device placement, signal conduction, and isolation from environments detrimental to the sensory device storage and integrity prior to utilization.

In one embodiment, the present invention provides solutions for at least some of the drawbacks discussed above. The invention relates to the electronically controlled actuation of a lancet to create a wound for the collection of a blood sample for analysis. Specifically, some embodiments of the present invention provide an improved fluid sampling device. Because of the obtain spontaneous blood generation ina relatively painless manner, the ability to move the penetrating member at a high, yet controllable velocity is of interest. At least some of these and other objectives described herein will be met by embodiments of the present invention.

In another aspect of the present invention, the invention relates to using the electronic tissue penetration device to drive a penetrating member into tissue, wherein a elastomeric portion actuated by the electronic device to drive the penetrating member. More specifically, the invention relates to the electronic actuation of a lancet through the use of an elastomeric capacitor that can be made to change length with the application of voltage across the capacitor plates.

In one embodiment, a method of body fluid sampling is provided. The method comprises moving a penetrating member at conforming to a selectable velocity profile or motion waveform by using electricity to actuate an elastomeric device and measuring the position of the penetrating member. In some embodiments, the device will use the position data to create a feedback loop wherein the actuator will move the penetrating member at velocities that follow a desired trajectory.

Still further, the present invention provides solutions for at least some of the drawbacks in designing medical devices. The technical field relates to methods for designing microscale devices. Because the difficulty of building such sensors for testing, the ability of the present invention to accurately model the microscale device is of interest. Specifically, some embodiments of the present invention provide an improved method and model for developing such microscale devices. At least some of these and other objectives described herein will be met by embodiments of the present invention.

Embodiments of the present invention disclosed herein comprise the use of a mathematical modeling algorithm to develop a list of design rules for dispersed-phase-based biosensors. Furthermore, various pieces of hardware as well as embodiments of a glucose detecting member are disclosed.

The system may further comprise means for coupling the force generator with one of the penetrating members.

The system may further comprise a penetrating member sensor positioned to monitor a penetrating member coupled to the force generator, the penetrating member sensor configured to provide information relative to a depth of penetration of a penetrating member through a skin surface.

The depth of penetration may be about 100 to 2500 microns.

The depth of penetration may be about 500 to 750 microns.

The depth of penetration may be, in this nonlimiting example, no more than about 1000 microns beyond a stratum corneum thickness of a skin surface.

The depth of penetration may be no more than about 500 microns beyond a stratum corneum thickness of a skin surface.

5 The depth of penetration may be no more than about 300 microns beyond a stratum corneum thickness of a skin surface.

The depth of penetration may be less than a sum of a stratum corneum thickness of a skin surface and 400 microns.

10 The penetrating member sensor may be further configured to control velocity of a penetrating member.

The active penetrating member may move along a substantially linear path into the tissue.

The active penetrating member may move along an at least partially curved path into the tissue.

15 The driver may be a voice coil drive force generator.

The driver may be a rotary voice coil drive force generator.

The penetrating member sensor may be coupled to a processor with control instructions for the penetrating member driver.

20 The processor may include a memory for storage and retrieval of a set of penetrating member profiles utilized with the penetrating member driver.

The processor may be utilized to monitor position and speed of a penetrating member as the penetrating member moves in a first direction.

The processor may be utilized to adjust an application of force to a penetrating member to achieve a desired speed of the penetrating member.

25 The processor may be utilized to adjust an application of force to a penetrating member when the penetrating member contacts a target tissue so that the penetrating member penetrates the target tissue within a desired range of speed.

30 The processor may be utilized to monitor position and speed of a penetrating member as the penetrating member moves in the first direction toward a target tissue, wherein the application of a launching force to the penetrating member is controlled based on position and speed of the penetrating member.



The processor may be utilized to control a withdraw force to the penetrating member so that the penetrating member moves in a second direction away from the target tissue.

5 In the first direction, the penetrating member may move toward the target tissue at a speed that is different than a speed at which the penetrating member moves away from the target tissue.

In the first direction the penetrating member may move toward the target tissue at a speed that is greater than a speed at which the penetrating member moves away from the target tissue.

10 The speed of a penetrating member in the first direction may be the range of about 2.0 to 10.0 m/sec.

The average velocity of the penetrating member during a tissue penetration stroke in the first direction may be about 100 to about 1000 times greater than the average velocity of the penetrating member during a withdrawal stroke in a second direction.

15 A further understanding of the nature and advantages of the invention will become apparent by reference to the remaining portions of the specification and drawings.

#### BRIEF DESCRIPTION OF THE DRAWINGS

20 Figure 1 is an exploded view of one embodiment of a cartridge with sealing layer and analyte detecting layer according to the present invention.

Figure 2 shows a close-up view of one portion of the cartridge of Figure 1.

Figures 3A-3H show examples of geometries for texturing formations.

Figure 4 shows a perspective view of a ring of analyte detecting members that may have texturing.

25 Figure 5 shows another embodiment of the present invention with texturing.

Figure 6 shows a cross-section view of yet another embodiment of the present invention with texturing.

Figure 7 shows one embodiment of a mesh for use with the present invention.

30 Figure 8 shows perspective views of a fluid sampling device and a cartridge for use with such a device.

Figure 9 shows a close-up view of one embodiment of a cartridge using mesh.

Figures 10-14 show other views of embodiments of mesh for use with the present invention.

Figure 15 shows one embodiment of electrical contacts and leads for use with the present invention.

5 Figure 16 shows one embodiment of the present invention with contact pads for use with commutators.

Figure 17 shows an exploded view of a cartridge with an analyte detecting member layer.

10 Figure 18 shows a perspective view of one embodiment of the present invention for use with commutators on the inner diameter of the cartridge.

Figure 19 shows a cross-sectional view of one embodiment of the present invention.

Figure 20 shows yet another embodiment of the present invention.

Figures 21-22 show side views of actuators according to the present invention.

15 Figures 23A-23B show two different embodiments of actuators according to the present invention.

Figure 24 is a schematic for determining position for an actuator according to the present invention.

Figures 25A-25D show penetrating member velocity profiles.

20 Figure 26 is a schematic showing one embodiment of feedback control for a penetrating member.

Figures 27A and 27B are perspective views of a fluid sampling device and a cartridge for use with such a device.

25 Figure 28 is a diagram showing the analyte detecting member as modeled after initial contact of the member and the fluid sample.

Figures 29a and 29b are charts showing reaction rates of enzyme reactions on the sample-sensor interface.

Figure 30a and 30b are charts showing concentrations profile of enzymes along the sample-sensor interface.

30 Figure 31a through 31c are charts showing concentrations of reactants along the sample-sensor interface.

Figure 32 is chart showing change in fluorescence lifetime as a function of analyte detecting member response to glucose.

Figure 33a and 33b are charts showing simulated dynamic calibration (33a) and response (33b) graphs of modeled glucose analyte detecting member.

5 Figure 34 shows experimentally obtained response curve of an analyte detecting member designed according to the model predictions according to the present invention.

### DESCRIPTION OF THE SPECIFIC EMBODIMENTS

10 The present invention provides a multiple analyte detecting member solution for body fluid sampling. Specifically, some embodiments of the present invention provides a multiple analyte detecting member and multiple penetrating member solution to measuring analyte levels in the body. The invention may use a high density design. It may use penetrating members of smaller size, such as but not limited to diameter or  
15 length, than known lancets. The device may be used for multiple lancing events without having to remove a disposable from the device. The invention may provide improved sensing capabilities. At least some of these and other objectives described herein will be met by embodiments of the present invention.

It is to be understood that both the foregoing general description and the following  
20 detailed description are exemplary and explanatory only and are not restrictive of the invention, as claimed. It must be noted that, as used in the specification and the appended claims, the singular forms "a", "an" and "the" include plural referents unless the context clearly dictates otherwise. Thus, for example, reference to "a material" may include mixtures of materials, reference to "a chamber" may include multiple chambers, and the  
25 like. References cited herein are hereby incorporated by reference in their entirety, except to the extent that they conflict with teachings explicitly set forth in this specification.

In this specification and in the claims which follow, reference will be made to a number of terms which shall be defined to have the following meanings:

30 "Optional" or "optionally" means that the subsequently described circumstance may or may not occur, so that the description includes instances where the circumstance occurs and instances where it does not. For example, if a device optionally contains a feature for analyzing a blood sample, this means that the analysis feature may or may not

be present, and, thus, the description includes structures wherein a device possesses the analysis feature and structures wherein the analysis feature is not present.

Figure 1 shows one embodiment of a radial cartridge 20. The cartridge 20 may include a sterility barrier 22 and a substrate 24 having a plurality of analyte detecting  
5 members 26. In this embodiment, the cartridge 20 is designed so that blood will enter the fluid chamber 30 and be held there for analysis.

Referring now to Figure 2, a close up view of one embodiment of the sample chamber 30 is shown. As discussed, it is often desirable to have a hydrophilic surface in certain areas when trying to create fluid flow. However, as seen in Figure 2, having a flat  
10 surface that is hydrophilic may cause the fluid sample 32 to spread all over the sample chamber 30.

In one embodiment of the present invention, surface texturing may be used to address the issue. Although not limited to the following, texturing may also be combined with chemical surface treatments or other surface treatments. To design the texture, one  
15 may need to account for the surface tension (contact angle), the bulk properties (density, etc..) and surface flow. Since the volumes that the present invention deals with may be, as a nonlimiting example, in the area of about 250-500nl, just having blood flow around, is something that the device cannot afford. It is desired that the fluid flow be a shaped flow, because at low volumes, the fluid cannot be wasted on errant flows.

At low volumes, there is no conservation, and the blood goes everywhere. For  
20 one nonlimiting example where it is desired that the blood or fluid goes into a tube. However, the preferential path is the surface and until the tube fills completely and creates a pressure differential, the blood is not all going in there. The blood could try to pull but the fluid could "break" and then not all of the blood is pulled into the tube and  
25 into the device for measurement.

In one embodiment, the present invention essentially involves texturing to direct the flow. For example and not limitation, the texturing may be on the cartridge 20 or it may be along fluid paths formed by the cartridge 20. This is one solution for tubular designs (i.e. capillary tube). Playing with the flow equation allows for designing of the  
30 texturing, but meshes are different animals since they create increased surface area. The tubular problem, such as guiding fluid into a sensor area or a capillary tube involves positioning the fluid to engage the capillary. In one embodiment, a single material is

used. The material may be an ideal flow material for use with a single molding. Multiple moldings/laminated moldings may be used. As a nonlimiting example, materials may have a contact angle in the area of about 20 to 5 degrees.

5 Figures 3A-3H show examples of geometries that may be used with the present invention. These are purely exemplary and are nonlimiting. Additionally, roughing or texturing the surface may improve user feedback, letting them know whether they are on target. It might help with the sensation of contact. The texturing may be dimples, raised portions, detents, depressions, cross-hatch, scoring, criss-cross, triangles, any of a variety of other surface geometries, and/or any single or multiple combinations of the above.

10 Figure 3A shows an embodiment where the texturing 40 is in a circular structure shape around an opening 42 for receiving body fluid. In this embodiment, the texturing 40 is designed to "corral" fluid towards the opening 42. Figure 3B show texturing 44 in a parabolic shape. As seen in Figure 3B, the texturing does not necessarily fully surround the opening 42. Figure 3C shows texturing 46 in an elliptical configuration. Figure 3D shows texturing 48 in a horseshoe configuration. Figure 3E shows texturing 50 in a box configuration. Figure 3F shows texturing 52 in a rectangular configuration. Figure 3G shows texturing 54 in a curved-linear configuration. Figure 3H shows texturing 56 in a teardrop-heart shape. It should be understood that polygonal, hexagonal, triangular, or other shapes may also be used. The texturing can be placed on any surface and is not limited to being placed on the surface shapes shown. Some embodiments may have single or multiple combinations of the above shapes.

15 For changing surface property of Teflon and other materials, you can chemically attack it. As an example, the chemical attack may result in about 30 angstroms of surface change. By texturing, it forms and stays in that ring. But in the middle it starts to move into the sensor area (since the other areas are corralled). In some embodiments, a funnel area may be located at center of the "corral". We are affecting the surface properties by texturing.

20 As a nonlimiting example, the texturing may be used with a typical 300 micron diameter lancet. The blood droplet could form anywhere on the lancet. It's also a C-shaped wound created on the patient. The cutting edge creates that shape. Anywhere around this, droplet can go in the center, or anywhere around the C. That why the texturing is used to corral fluid that may hit the surface and need to be guided. In some

embodiments, there could be gaps in the texturing so that fluid and directed in certain directions.

Types of texturing includes but is not limited to lumpy, bumpy (just texturing) round dots, square dots, etc... Texturing may be formed by any variety of techniques including but not limited to aiming a plasma beam to create the texturing; sacrificial  
5 foam/hot press embossing; chemical texturing, combinations of the above, and other techniques as known in the art.

Referring now to Figure 4, one embodiment of a ring 60 for use with a cartridge such as that shown in Figure 1, will now be described. This embodiment of a ring 60  
10 having a plurality of analyte detecting members 62 is shown. For example and not limitation, the ring 60 may be formed a linear tape of analyte detecting member 62 formed into a circular configuration. The analyte detecting member 62 may include an aperture 64 to allow for a penetrating member (not shown) to pass through to penetrate tissue. In the present embodiment, the analyte detecting member 62 may have three  
15 electrodes 68, 70, and 72. The electrodes are coupled to the appropriate electrical contacts 74. The present invention may also include texturing 40 on the analyte detecting member 62.

It should be understood that in some embodiments, the linear tape of analyte detecting members 62 may be "folded" in a reverse manner so that the outer surface 80 of  
20 the ring 62 will now be the inner surface (or inner diameter) of the ring 62. Thus the leads 74 will be on the inner surface and the plain backing 82 will now face outward. In such a configuration, the backing 82 would now have the texturing as shown in Figures 3A-3H. Having this reverse configuration allows the electrodes to be on the side of the analyte detecting member that first receives body fluid as indicated by arrow 1234. The  
25 embodiment of Figure 4 may also be formed or attached to the outer circumferential surface of the cartridge.

Referring to Figure 4, the orientation of the analyte detecting members 62 is orthogonal to the orientation of the penetrating member. The penetrating member moves through the aperture 64, through a sample capture port (not shown) to pierce into the skin  
30 or tissue and retract. In one embodiment, the blood sample may move by capillary or wicking action across the electrodes 68, 70, and/or 72. There may be wicking material used on all or part of the sample capture or transport area. The sample volume for this

configuration is relatively small, less than 300 nl. In some embodiments, the amount in the analyte detecting member is about 60 to 70 nl. The required space for the capillary and electrodes is relatively small, less than 20 mm<sup>2</sup>. In one embodiment, the range of the aperture 64 is about 0.5 – 1.0 mm.

5 Figure 5 shows yet another embodiment of the present invention which may use texturing 40. This embodiment may use individual analyte detecting members 90 and mated with a cage 92 to hold them in position for use with a disc or cartridge containing a plurality of penetrating members. The cage 92 may be integrally formed with the cartridge 20 holding the plurality of penetrating members or it may be formed separately  
10 and then coupled to the cartridge. As seen in Figure 5, some embodiments of the device may have fewer than 50 penetrating members, such as but not limited to 17, 20, 25, 30, or 40 penetrating members.

Referring now to Figure 6, a cross-section of yet another embodiment of the present invention will now be described. This cross-section shows a cartridge 100  
15 holding a penetrating member 102 in a cavity 104. From a wound created in target tissue by the penetrating member 102, body fluid will contact electrodes 108 positioned around the exit port 110 of the penetrating member 102. It should be understood that the electrodes 108 may be arranged in a variety of configurations about the exit port 110. Some embodiments may have all the electrodes 108 below the port 110. Some  
20 embodiments may have all of the electrodes 108 above the port 110. Some may have the members 108 distributed about the opening. Some embodiments may have a mesh that covers the members 108 or comes next to the members and brings body fluid to the members 108. In still other embodiments an outer ring portion 114 maybe formed separate from portion 116 and then the two portions are integrally joined to form a single  
25 integral unit. The joining may occur by adhesives, bonding, heat bonding, interlocking coupling, or other methods. This may facilitate manufacture of parts that may use different sterilization methods. A sterility seal (not shown) such as but not limited to a foil may be placed over the outer circumference of the ring and may be peeled back to open each individual port 110. In other embodiments, the sterility seal may be punched  
30 open by a device such as but not limited to a separate punch device, the penetrating member, or a combination of the two. By example and not limitation, the device may

include texturing 48 around the electrodes 108 or a larger area of texturing 40 that surrounds all the electrodes at once (not shown).



Referring now to Figure 7, one embodiment of the present invention will now be described. Rather than let a droplet of body fluid build on the surface, one concept is to pull the droplet from the surface with, as a nonlimiting example, a fine mesh 120 that is located between the penetrating member and the finger. Figure 7 shows a top down view of a radial cartridge 121 having the fine mesh 120. At the start position, the lancet mesh 120 may be located between the lancet tip and the foil. When cutting the foil, prior to the lancing event, the cutting instrument will spare the fragile mesh. In this embodiment, the amount of foil can be relatively limited because the mesh will be able to wick the blood down to the analyte detecting member. With the lancet tip being very sharp, the mesh 120 would be pushed to the side rather than cut. The resulting ring of capillary fibers around the wound channel would be available after the lancet was retracted to wick the blood sample into the sample channel.

Figure 8 shows the radial cartridge 121 for use with a lancing device 130. The radial cartridge 121 may be sealed with a sterility barrier 132 and be coupled to analyte detecting members mounted on a substrate 34. A suitable device is described in commonly assigned, copending U.S. Patent Application No. \_\_\_\_\_ (Attorney Docket No. 38187-2662) fully incorporated herein by reference for all purposes.

Referring now to Figure 9, as described above, when a penetrating member 40 is actuated and extends outward from the cartridge 121, the mesh 120 is pushed aside or pierced by the exiting member 140. The resulting ring of capillary fibers 142 around the wound channel would be available after the lancet was retracted to wick the blood sample into the sample channel.

The physical characteristics of the mesh 120 is one aspect for successfully transport of blood to the analyte detecting member 150. In one embodiment, the mesh 120 could be pliable enough to allow relaxation, but maintain contact or near-contact with the skin surface. An active region could be striped on the mesh to allow the blood to only travel in the direction towards the analyte detecting member. A different gauge capillary fiber may be used on the mains versus the cross. In another embodiment, the mains may have a smaller gauge and higher pitch to promote vertical movement. As an additional benefit, if the mesh assisted in distributing the force of lancet impact with the skin, the cutting efficiency of the lancet could be increased.

In another embodiment, the mesh 120 would reduce the amount of micropositioning used to assure that the droplet of body fluid gets to the analyte detecting member. The potential volume required by the analyte detecting member could be reduced by reducing the amount of blood or body fluid that spontaneously rises to the surface of the skin that is either not removed from the skin once the surface tension is released in a traditional, microfluidics methods. Traditional microfluidics could also have a higher volume required to get the blood to the sample chamber.

Referring now to Figure 10, it should be understood that the mesh may be configured to a variety of geometries. The mesh 120 could be fabricated as a ring as seen in Figure 7 and then heat sealed into the analyte detecting member. The heat sealing should not effect the integrity of analyte detecting member. By example and limitation, the mesh 120 may also be used to cover at least one or more electrodes 68, 70, and 72 used in the device of Figure 4. In some embodiments, the mesh 120 may also be used to cover the aperture 64.

As seen in Figure 11, the mesh 120 may be configured so that a blood droplet 160 that hits the mesh 120 will be drawn toward the analyte detecting member 150 as indicated by arrow 162, due to the length of the mesh 120 which is extended down to the member 150. As seen in Figure 10, which is a top down view, the mesh 120 has portions 164 which may be extended down towards the member 150.

In one embodiment, a capillary mesh may be used that basically allows the lancet to fire through or the lancet can come around or through a lancet aperture in the mesh. The mesh in one embodiment may be a hydrophilic mesh that would then allow the blood to be absorbed, in this embodiment, once the droplet is built up on skin. With mesh, it does not matter where the droplet hits it. With a certain volume, there is enough blood to coat the mesh and coat the analyte detecting member, thus creating a better solution for integrated analyte detecting member.

Figure 12 shows one embodiment where the force of the penetrating member 140 impacting the mesh 120 flattens it out and pushes it against the skin. In this particular embodiment of mesh 120, the mesh 120 is pliable enough to allow relaxation.

One issue associated with the present invention may be getting the analyte detecting member close enough to the lancet. In many embodiments, the radial axis of

the lancet is going to be where the droplet of body fluid is going to form. The pickup or transport is going to have to come to the droplet to acquire it.

In one embodiment, a layer of body fluid at least 50-100 microns thick is desired, and this is the thickness that the electrode needs to generate the glucose signal. So if the mesh is sandwiched on top of the electrode or if fluid is wicked along the capillary mesh,  
5 it is possible to repeatable transport blood to the analyte detecting member. Electrodes tend to be hydrophobic. But if there is a hydrophilic mesh, it will still travel to the mesh, even though the surface energy is low.

In another embodiment, a particularly high energy capillary mesh can be co-  
10 located at where the droplet is going to come which is at the axis of the lancet travel. The wicking member would be heat sealed to the electrode. Most preferable is a design where the wick is at about 90 degrees (i.e. vertical) as seen in Figure 13.

Referring now to Figure 14, it should be understood that the mesh may be a gradient type of mesh. It may have high energy to pull one way as indicated by arrows  
15 180. The crosses and the mains on the mesh may be designed and patterned to created a desired movement of fluid in contact with the mesh. The resulting effect is a gradient. A thinner gauge may be used in a higher energy area. With regard to the capillary size and the gaps, they are relatively proportionate. Of course, when you get down to a level  
20 below 100 microns, 70 microns for the pore size, the mesh can get into blood filtration or clogging of the blood, particulates such as the big lucocytes tend to clog and make the mesh unproductive/effective anyways. There is a limit to how much you can play with sizing of the mesh strands.

It should be understood, of course, that the present invention may operate with alternative embodiments. With the mesh, you may be able to use a hydrophilic spray. Or  
25 to create a highly texturized surface or other surface treatment, the mesh may direct the flow of fluid. In some alternative embodiments, a ribbed plastic without pores may be used. One limitation of traditional capillary structure is that when it gets too close to the skin, it tends to blanch or inhibit the movement of blood to the surface. So even if you have it perfectly located in a lateral, collateral direction. Such a capillary structure is  
30 vertically sensitive and sometimes does not get the blood as a result.

If the mesh is very compliant, then the vertical sensitivity problem/blanching is substantially resolved. The mesh could be co-located perfectly and touching the surface

of the skin. And then you do not have a vertical offset or a vertical insensitivity problem that tends to blanch. Then because there is not a bearing surface there and pressure is kept at a level below that which would cause blanching.

Figures 15 and 16 provide additional details of the line conductors, feed-throughs, and conductor pads. The embodiment shown in the Figures 15 and 16 may be adapted for use with a radial cartridge such as that shown in commonly assigned, co-pending U.S. Patent Application Ser. No. 10/429,196 (Attorney Docket No. 38187-2662) filed May 1, 2003, fully incorporated herein by reference for all purposes. For example and not limitation, figure 15 shows a support structure 212 that is adapted for use with a radial cartridge 20. The support 212 may include a plurality electrodes such as, but not limited to, a working electrode 240, a counter electrode 242, and a reference electrode 244. A plurality of conduction lines 250 may be used as leads to connect the electrodes having the sensory material 214 with the contact pad 230 on the other side of the support 212 (see Figure 16). By example and not limitation, the contact pad 230 may be substantially larger in width than the conduction lines 250. This facilitates the tolerance of the pad to slight misalignments of the pad with connectors or contacts on a measurement device. The contact pads 230 are shown to be square or rectangular in geometry. It should be understood, however, that the contact pads 230 may be circular, oval, polygonal, triangular, any single combination of the geometries above, or any combination of any number of the geometries above. The via holes may also be sufficiently spaced apart such that there is sufficient space on the underside of the support structure to accommodate the larger contact pads 230.

In the present embodiment, the top side of the support 212 may include a sealing region 260. This sealing region 260 may be used to keep the sensor material 214 in a sealed environment prior to use.

Figure 17 shows how one embodiment of a radial cartridge 201 may be coupled to a sterility barrier 203 and a support 212 having the sensor material 214 and contact pads 230. Of course, the support 212 of Figure 17 may be configured to include configuration shown in Figures 15 and 16. The support 212 would be sealed, in one embodiment, against the underside of the radial cartridge 201. This integrates the sensory material 214 with the cartridge and also creates the sealed environment in which the material 214 may be stored until ready for use.

Embodiments of the present invention take the sensor electrode contact pad which for example and not limitation, may be located anywhere on the bottom on the package taking advantage of the disc shape. The electrode contact pads may be placed anywhere

along the disc (between ID and OD). A commutator pickup may be used to make electrical contact. In one embodiment, a million insertion point probe may be used that is spring-loaded into the door or housing of the device. Other embodiments, by way of example and not limitation, may use gold plated sheet metal probes that are bent up. As the disc-shaped cartridge rotates, the next chamber rotates right in line with the contacts.

5 Referring now to Figure 18, one embodiment of the present invention could use a commutator 200 to engage the electrode leads 202. The commutator 200 may be spring loaded to better engage the leads. As the cartridge rotates as indicated by arrows 204, those lead from electrodes in the active regions come in contact with the commutator 200.

10 Referring back to Figure 16, it can be seen that commutators 200 may be positioned to engage contact pads from the leads, where the pads 230 are not positioned in the inner diameter of the cartridge. The pads 230 may be on the underside, side, or somewhere along the length of the cartridge. It should be understood that a variety of commutators 200 are shown in Figure 18. The device may have one set of commutators or it may have

15 multiple sets. They may all have the same orientation or combinations of orientations. Figure 18 shows side by side, vertical, and spring based versions. These are purely exemplary and are nonlimiting.

Referring now to Figure 19, other embodiments may have the commutators on the outer diameter of the cartridge. Figure 19 shows a cross-section of yet another

20 embodiment of the present invention will now be described. Figure 19 shows a cartridge 20 with a penetrating member 102. In one embodiment, a ring portion 270 is coupled to the cartridge 20. In some embodiments, the ring portion 270 may be integrally formed with the cartridge 20. In other embodiments, the two portions are integrally joined to form a single integral unit. The joining may occur by adhesives, bonding, heat bonding,

25 interlocking coupling, or other methods. This may facilitate manufacture of parts that may use different sterilization methods. An opening 273 may be provided to allow any sterility seals on the cartridge 20 to be opened. A punch or other mechanism may extend down through the opening 273 to pierce the seal and clear it from the path of the penetrating member 102.

30 As seen in Figure 19, an analyte detecting member 275 may be housed in the portion 270. The analyte detecting member 275 may be similar to embodiments shown in Figures 110-112. A groove 1330 in the portion 270 may be formed to hold the member

275. A plurality of analyte detecting members 275 may also be placed on a ribbon and then placed in a groove 277 that runs around the circumference of the disc. Openings 279 allow for the penetrating member to exit. By way of example and not limitation, some embodiments may have texturing 40 around the openings 279 to control any wayward fluid flow. The texturing 40 may also be present on the detecting member 275.

Figure 19 also shows that commutators 200 may also be used with the present invention. In some embodiments the commutators 200 may be spring loaded to press against contacts 281 to ensure a solid contact. By way example and not limitation, the contacts 281 and commutators may also be on the inner diameter of the analyte detecting member 275. Other embodiments may have the contacts 281 on the bottom of the analyte detecting member 275. Some embodiments may have the members 275 extend below the bottom surface of the cartridge 20 to facilitate engagement with the commutators 200. Other embodiments may have the bottom of the detecting member 275 substantially flush with the bottom surface of cartridge 20. The contact pad 281 may be on the bottom surface of the detecting member 275. In some embodiment, there may be a groove 283 (shown in phantom) that allows for commutators 200 to engage any contact pads on the inner diameter. In some embodiments, a similar groove may be on the outer diameter side to facilitate contact with contact pads on that side.

Referring now to Figure 20, a still further embodiment of the present invention will be described. In one embodiment of the lancing device, the cartridge goes in, foil-side up. If we print on sensors 218 in the chamber, you could have the probes 220 go through the printed material 224, making contact with the sensors. In this embodiment, electrodes at all. In some alternatives, cam action may be used to move the probes out of the way. They go back in, making contact with the next chamber when the cartridge is rotated into place. Thus to get rid of the electrodes, we want to make contact with the printed sensor using a needle probe which may be made by way of example and not limitation, laser etched gold. Alternative embodiments may use laminates. They use various thicknesses of materials. In some embodiments, the probes do not penetrate the sensors in a manner that contacts blood.

Referring now to Figure 21, an embodiment of the present invention using an elastomeric actuator will now be described. The present invention consists of an electronic actuator 300 consisting of a soft elastomer sheet 302 with electrodes 304 applied to the opposing large surfaces. The geometry created is that of a capacitor. When  
5 electrical potential is applied to the electrodes, electrostatic forces attract the electrodes toward each other. As seen in Figure 22, the intervening soft elastomer is displaced by the electrodes, lengthening the elastomer. This displaced material 310 acts to elongate the elastomer/electrode assembly. Because the elastomer grows in length, it is desirable in one embodiment to construct the electrodes from a compliant material, such as carbon-  
10 loaded silicone (SRI patent), so they can conform to the elongated elastomer.

It has been observed that pre-stretching the elastomer (SRI) improves resistance to dielectric breakdown, and an extension of the operating voltage range. The actuator embodiment shown in Figure 23A consists of a rigid frame 312 with a clamp 314 at one end to hold the elastomer. At the other end of the frame a guide bearing holds an actuator  
15 shaft that is clamped to the other end of the elastomer 316. A pre-stretch spring 318 tensions the elastomer. A controlled voltage source 319 applies actuating voltage to the electrodes on the elastomer.

A second style of actuator shown in Figure 23B consists of a pre-tensioned diaphragm 330 stretched over a chamber. In this embodiment, an actuator shaft 332 is  
20 attached to the center of the diaphragm 330, and may be guided by a bearing (not shown) if needed. Electrodes applied to the diaphragm 330 cause it to expand. To shape the diaphragm, and direct the resulting motion, a bias pressure from a source 334 is applied behind the diaphragm. The same function can be achieved by adding a bias spring to the actuation shaft.

Referring now to Figure 24, one component of an actuator system is position  
25 feedback. A position signal can be obtained from an elastomeric actuator by measuring the capacitance of the actuator 330 (or 316). This can be accomplished by imposing a sine wave, or pulse signal 320 onto the DC drive voltage. The current resulting from this sensing signal is a measure of the capacitance of the actuator, and hence the deflection of  
30 the electrode plates.

As seen in Figures 25 and 26, a variety of feedback systems and velocity profiles may be used to control the motion provided by actuator 330 or 316. As discussed above,



tissue penetration devices which employ spring or cam driving methods have a symmetrical or nearly symmetrical actuation displacement and velocity profiles on the advancement and retraction of the penetrating member as shown in Figures 25 and 26. In most of the available lancet devices, once the launch is initiated, the stored energy  
5 determines the velocity profile until the energy is dissipated. Controlling impact, retraction velocity, and dwell time of the penetrating member within the tissue can be useful in order to achieve a high success rate while accommodating variations in skin properties and minimize pain. Advantages can be achieved by taking into account of the fact that tissue dwell time is related to the amount of skin deformation as the penetrating  
10 member tries to puncture the surface of the skin and variance in skin deformation from patient to patient based on skin hydration.

In this embodiment, the ability to control velocity and depth of penetration may be achieved by use of a controllable force driver where feedback is an integral part of driver control. Such drivers can control either metal or polymeric penetrating members or any  
15 other type of tissue penetration element. The dynamic control of such a driver is illustrated in Figure 25C which illustrates an embodiment of a controlled displacement profile and Figure 25D which illustrates an embodiment of a the controlled velocity profile. These are compared to Figures 25A and 25B, which illustrate embodiments of displacement and velocity profiles, respectively, of a harmonic spring/mass powered  
20 driver. Reduced pain can be achieved by using impact velocities of greater than about 2 m/s entry of a tissue penetrating element, such as a lancet, into tissue. Other suitable embodiments of the penetrating member driver are described in commonly assigned, copending U.S. Patent Application Ser. No. 10/127,395 (Attorney Docket No. 38187-2551) filed April 19, 2002 and previously incorporated herein.

25 Figure 26 illustrates the operation of a feedback loop using a processor 360. The processor 360 stores profiles 362 in non-volatile memory. A user inputs information 364 about the desired circumstances or parameters for a lancing event. The processor 360 selects a driver profile 362 from a set of alternative driver profiles that have been preprogrammed in the processor 360 based on typical or desired tissue penetration device  
30 performance determined through testing at the factory or as programmed in by the operator. The processor 360 may customize by either scaling or modifying the profile based on additional user input information 364. Once the processor has chosen and

customized the profile, the processor 360 is ready to modulate the power from the power supply 366 to the penetrating member driver 368 through an amplifier 370. The processor 360 may measure the location of the penetrating member 372 using a position sensing mechanism 374 through an analog to digital converter 376 linear encoder or other such transducer. Examples of position sensing mechanisms have been described in the 5 embodiments above and may be found in the specification for commonly assigned, copending U.S. Patent Application Ser. No. 10/127,395, (Attorney Docket No. 38187-2551) filed April 19, 2002 and previously incorporated herein. The processor 360 calculates the movement of the penetrating member by comparing the actual profile of the 10 penetrating member to the predetermined profile. The processor 360 modulates the power to the penetrating member driver 368 through a signal generator 378, which may control the amplifier 370 so that the actual velocity profile of the penetrating member does not exceed the predetermined profile by more than a preset error limit. The error limit is the accuracy in the control of the penetrating member.

15 After the lancing event, the processor 360 can allow the user to rank the results of the lancing event. The processor 360 stores these results and constructs a database 80 for the individual user. Using the database 379, the processor 360 calculates the profile traits such as degree of painlessness, success rate, and blood volume for various profiles 362 20 depending on user input information 364 to optimize the profile to the individual user for subsequent lancing cycles. These profile traits depend on the characteristic phases of penetrating member advancement and retraction. The processor 360 uses these calculations to optimize profiles 362 for each user. In addition to user input information 364, an internal clock allows storage in the database 379 of information such as the time of day to generate a time stamp for the lancing event and the time between lancing events 25 to anticipate the user's diurnal needs. The database stores information and statistics for each user and each profile that particular user uses.

In addition to varying the profiles, the processor 360 can be used to calculate the appropriate penetrating member diameter and geometry suitable to realize the blood 30 volume required by the user. For example, if the user requires about 1-5 microliter volume of blood, the processor 360 may select a 200 micron diameter penetrating member to achieve these results. For each class of penetrating member, both diameter and penetrating member tip geometry, is stored in the processor 360 to correspond with

upper and lower limits of attainable blood volume based on the predetermined displacement and velocity profiles.

The lancing device is capable of prompting the user for information at the beginning and the end of the lancing event to more adequately suit the user. The goal is to either change to a different profile or modify an existing profile. Once the profile is set, the force driving the penetrating member is varied during advancement and retraction to follow the profile. The method of lancing using the lancing device comprises selecting a profile, lancing according to the selected profile, determining lancing profile traits for each characteristic phase of the lancing cycle, and optimizing profile traits for subsequent lancing events.

An article titled Artificial Muscles in the October 2003 issue of Scientific American is incorporated herein by reference for all purposes.

Referring now to Figure 27, yet another embodiment of the present invention will now be discussed. Mathematical modeling of microscale processes is a uniquely useful alternative to the known approaches since the chemical and physical processes in the microscale generally follow deterministic physical laws that can be accurately represented in mathematical models. Once validated by external measurements, modeling can predict internal behavior at any point in space and time within the microdevice, leading to new insights and optimization techniques, e.g., the accurate fitting of non-linear response functions, optimization of system dynamics, or location of a specific region of incomplete reagent mixing, complete with design modifications that will remedy the problem.

Many developers of microdevices utilize this very powerful approach of simultaneous modeling and experimentation. Microscale fluid movers have been developed using both linear<sup>3-5</sup> and nonlinear<sup>6-8</sup> modeling, even when complex fluids such as particle suspensions<sup>10,11</sup> are involved. Other components of microfluidic systems<sup>12-17</sup> have benefited from this dual approach as well.

The large surface-to-volume ratio characteristic of microdevices, however, frequently leads to unexpected behaviors. For example, microvolumes of physiological fluids evaporate, cool, and heat extremely rapidly and modeling is often desirable to accommodate, or leverage, such heat transfer and evaporation processes and their impact on the system. At the typical low Reynolds-number (slow flows) in microdevices, mixing is often problematic and modeling guides the design to achieve mixing requirements.

The modeling of laminar flow is rarely an end in itself, but since the exact governing equations can be solved analytically in simple channels, or numerically in more complex channels, this produces valuable knowledge of the flowfield and its effect on other important physical processes, for example the precise control of chemical reaction rate by designing the diffusive mixing of the reactants. A multiphysics model is the result and is extremely useful to experimentalists tasked with sorting out the effects of a microdevice with complex physics. Many researchers have utilized this approach to develop devices for fluid constituent extraction<sup>18</sup>, property measurement such as pH<sup>19</sup>, viscosity<sup>20</sup>, and diffusion coefficient<sup>21</sup>, quantitative analysis<sup>22</sup>, sample preparation<sup>23</sup>, and laminate-based microfluidic devices for biomedical applications<sup>24-28</sup>.

To illustrate how modeling can speed the development of diagnostic products, the present application discusses using one embodiment of the present invention to model a microscale processes to speed development of a microfabricated glucose detecting member.

5 Referring now to Figures 27A and 27B, effort has been made to develop a novel microfabricated point-of-use glucose detecting member to be integrated within an automated low-volume lancet-based blood collection device. In a nonlimiting embodiment, the blood collection device is optimized to achieve almost painless blood acquisition of approximately 200 nL per sample (1/100<sup>th</sup> of a drop of blood). It should be understood, of course, that other volumes such as about 500nl, 400nl, 300nl, 200nl, 100nl, 10  
60nl or less can also be used in other embodiments of the invention. A new integrated glucose detecting member was developed to be compatible with such small fluid volumes, as well as, for example and not limitation, a sub-10 second response time and an accuracy of  $\pm 5\%$  over the clinical range. Figure 27B shows one embodiment of the  
15 prototype analyte detecting member arrangement as well as the integrated glucose lancing device. The analyte detecting members may be clustered in units of five for each sample measurement and within a microchannel along which a blood sample flows.

The present invention focuses here on the analyte detecting member itself, a new type of fluorescence-optical glucose biosensor. In one embodiment, the membrane  
20 comprises an emulsion that incorporates the enzyme glucose oxidase (GOX) to catalytically consume sample glucose and co-consume oxygen. The emulsion additionally contains an oxygen-quenchable fluorescent indicator that determines the concentration, and hence consumption, of oxygen within the analyte detecting member by a change in fluorescence and thus is related to the sample glucose concentration. The  
25 indicator is contained in dispersed hydrophobic droplets within a hydrophilic matrix containing GOX. The use of an emulsion enables single-step deposition of the analyte detecting member, avoiding much complexity in manufacturing and maintains optimal micro-environments for the GOX and the fluorescent indicator. Other significant advantages such as faster response times are expected.

The analyte detecting member model mathematically replicates the significant physical and chemical processes taking place in the analyte detecting member and sample. Figure 28 provides a simplified schematic of the most important processes.

Prior to contact between the sample and the analyte detecting member layers, the whole blood sample contains red blood cells (RBCs) at a given hematocrit level and plasma with dissolved oxygen (bound to hemoglobin inside the RBCs and equilibrated with the surrounding plasma), human catalase (with no significant exchange of catalase between RBCs and plasma), glucose (which is the analyte), and hydrogen peroxide. In this embodiment, the sample is assumed to contain no GOX at this point. Other blood constituents that diffuse into the analyte detecting member layer are not expected to have a significant impact on the analyte detecting member chemistry at the concentrations they can reach within 60 seconds after exposure.

Prior to sample contact, the analyte detecting member membrane (dispersed-phase) contains a fluorescent indicator in the form of a ruthenium complex immobilized within microdroplets of a hydrophobic material (a siloxane-containing polymer) that are of known concentration and size distribution and embedded in a continuous hydrogel matrix of known water, polymer, and GOX content (see photo in Figure 28). The membrane additionally has an oxygen concentration in equilibrium with the atmosphere.

When the analyte detecting member is initially exposed to the sample, the diffusion of all species is affected by the presence of the dispersed hydrophobic droplets; depending on the diffusion and partition coefficient of the each diffusing species, their diffusion rate may be increased or decreased. GOX starts to diffuse out of the analyte detecting member and into the sample at a slower rate than that of the small diffusants. As the glucose molecules reach the GOX molecules, they are metabolized and converted, with the co-consumption of oxygen and production of hydrogen peroxide, to gluconic acid, which in turn is instantaneously and non-reversibly hydrolyzed to gluconolactone.

In the present embodiment, the ruthenium complex (ruthenium-diphenylphenantroline  $\text{Ru}(\text{dpp})_3^{2+}$ ) in the hydrophobic microdroplets is initially in equilibrium with the ambient oxygen concentration, and its fluorescent lifetime is quenched to some degree. As oxygen is consumed by the GOX enzyme reaction a concentration gradient is generated between the hydrophobic microdroplets and the

surrounding hydrogel, causing the diffusion of oxygen out of the microdroplets. At the same time, oxygen from the plasma in the sample (continually replenished by the RBCs) is diffusing into the analyte detecting member and locally counteracting the reduction in oxygen concentration accomplished by the GOX enzyme reaction. The net effect is a location-dependent reduction in the oxygen concentration in the microdroplets. The dispersed ruthenium complex within the microdroplets is thus quenched to a value somewhere between the values for ambient and for about 0 mbar oxygen. By way of example and not limitation, fluorescence lifetimes for these systems tend to be in the low microsecond range.

#### 10 *Modeling Methodology*

In one embodiment of the present invention, the analyte detecting member model mathematically implements the physics of the analyte detecting member as described above. It divides the assay time into small time steps and the analyte detecting member into small control volumes. By way of example and not limitation, in the current embodiment, during each time step (and in each control volume), the model simultaneously solves a specie conservation equation for each important constituent: oxygen, glucose, glucose oxidase, catalase, and hydrogen peroxide. Each conservation equation includes an accumulation term, a diffusion term, and a production/destruction term. The latter relies on a production rate calculated either as a Michaelis-Menton reaction (catalase) or Ping-Pong Bi-Bi reaction (glucose oxidase).

The analyte detecting member model may track the diffusion of each important chemical component of the emulsion and sample, the chemical reactions between them, and the resulting signal from oxygen depletion. When the oxygen mass transfer rate between the hydrophobic droplet and surrounding hydrogel is as fast as the mass transfer rate of oxygen and glucose in the hydrophilic phase by diffusion, the concentration of oxygen in a droplet and the surrounding hydrophilic phase will always be close to equilibrium. This depends mainly on droplet diameter and diffusion coefficients, and is true for this analyte detecting member emulsion when the droplets are less than 5 microns in diameter. This rapid equilibration allows a welcome simplification in that the emulsion can be considered a single continuous material with averaged properties, instead of two

segregated materials, one for each phase, requiring constant updating of the local oxygen flux between them.

Thus, the analyte detecting member model treats the emulsion as a continuum with properties based on volume-fraction averages of the properties of the hydrophobic and hydrophilic phases. The volume-averaged properties include: diffusion coefficient,  
5 and hydrophilic phases. The volume-averaged properties include: diffusion coefficient, solubility, and initial concentrations of each conserved chemical species. Using oxygen concentration in the analyte detecting member membrane as an example, the initial concentration (mM) is

$$[O_2] = f_{Aq} S_{O_2 Aq} + f_{Si} S_{O_2 Si},$$

10 the effective partition coefficient is

$$H_{O_2} = f_{Aq} + f_{Si} \frac{S_{O_2 Si}}{S_{O_2 Aq}},$$

and the diffusion coefficient

$$D_{O_2} = f_{Aq} D_{O_2 Aq} + f_{Poly} (1 - f_{Si}) D_{O_2 Poly} + f_{Si} D_{O_2 Si}$$

where  $f_{Si}$  is the volume fraction of the emulsion that is hydrophobic phase,  $f_{Aq}$  and  
15  $f_{Poly}$  are the volume fractions of the hydrophilic phase that are aqueous and polymer, respectively. The diffusion coefficients of oxygen in water, hydrogel polymer, and hydrophobic phase are  $D_{O_2 Aq}$ ,  $D_{O_2 Poly}$ , and  $D_{O_2 Si}$ . Finally, the solubilities of oxygen in water and hydrophobic phase at initial conditions are  $S_{O_2 Aq}$  and  $S_{O_2 Si}$  in mM units.

Solution of each constituent's conservation equation, each impacted by chemical  
20 reactions with other constituents, produces the predicted concentrations of oxygen, glucose, glucose oxidase, catalase, and hydrogen peroxide at every location in the analyte detecting member membrane and sample, as shown in the Figures 29 to 33.

#### Results from Model and Experiment

The following sets of plots illustrate some of the information generated by the  
25 model and the corresponding experiment for one set of initial conditions and analyte detecting member parameters. In these plots we used glucose-loaded saline solutions to provide tightly-controlled samples.



Figure 29a shows the reaction rate for *catalase from Aspergillus niger* (as contaminant of GOX) and, in Figure 29b, *glucose oxidase from Aspergillus niger* as a function of cross-sectional distance through the sample (1 mm on the left) and analyte detecting member (0.047 mm). Enzyme reaction rates are in mM/s. The curves correspond to 5, 10, 15, and 20 seconds after the exposure of the analyte detecting member membrane to the sample. Both reactions occur almost solely in the analyte detecting member; their initial rates are the highest.

Figure 30 shows the *concentration of glucose oxidase from Aspergillus niger* (Figure 30a), and *concentration of catalase from Aspergillus niger* (as contaminant of GOX) (Figure 30b) across a sample and analyte detecting member cross section. Experiments have shown that the *A. niger* enzymes are somewhat immobilized in the analyte detecting member emulsion by an as yet unknown mechanism (possibly entrapment), diffusing approximately  $10^3$  times more slowly than if free. This reduction is implemented in the model, which only allows the normal diffusion speed in the sample. For the figures, Concentrations profile of enzymes are in mM.

Figures 31a-31c show the *concentrations of the reactants*: oxygen, freely dissolved in sample and analyte detecting member emulsion (Figure 31a), and hydrogen peroxide (Figure 31b) and glucose (Figure 31c), both freely dissolved in sample and analyte detecting member hydrophilic phase. For the figures, concentrations of reactants are in mM. These concentrations are affected by *both* diffusion and the consumption / production by chemical reactions over time. The decrease in oxygen concentration in the hydrophobic phase is the cause of the change in fluorescence lifetime. Figure 31b shows an increase in hydrogen peroxide concentration produced by the glucose oxidase activity; hydrogen peroxide that diffuses into the sample largely escapes the catalase reaction.

Figure 32 shows the change in fluorescence lifetime as a function of analyte detecting member response to glucose.

Figures 33a and 33b shows the *simulated dynamic response* of an analyte detecting member with good overall response characteristics: fast response, dynamic range in the physiologically important range, and a large enough signal change to be useful. The analyte detecting member has a hydrophobic to hydrophilic volume fraction of 40/60, an overall thickness of 47 micrometers, and 70% water in the hydrophilic phase.

Figure 33a shows a simulated calibration graph, plotted for different times after initial analyte detecting member exposure. The analyte detecting member shows a solid response over the whole glucose range in less than 10 seconds. Figure 33b shows simulated response curves, plotted for different glucose concentrations. In the present embodiment, the analyte detecting member reaches a plateau for the high glucose level after less than 10 seconds, while the medium and low glucose levels show an acceptable response over a similar time (in kinetic measurement mode). For reference, the normal range of glucose concentration in capillary blood is 3.5-6 mM. The 25 mM case represents an extremely high, critical glucose level. In Figure 33b, the signal for even the high glucose level never reaches a signal of 100%, which would be equivalent to complete consumption of all oxygen present in the analyte detecting member, but rather a steady state value above 95%. The discrepancy is due to oxygen diffusion from the sample. The fact that oxygen diffusion is relatively minor is advantageous as the analyte detecting member will not be significantly sensitive to variations in oxygen concentrations in the sample.

Figure 34 shows *test data* taken with a prototype analyte detecting member membrane using the same initial conditions and analyte detecting member parameters as supplied to the analyte detecting member model for the preceding figures. The predicted response (Figure 33b) agrees with the test data, especially at the higher glucose loading. The data from the prototype membrane displays some variability and a slightly reduced dynamic range compared to that predicted.

The model was highly useful in the beginning of the development project to predict that rapid (sub-10 second) response was indeed possible (at a time when the experiments still showed response time of minutes due to material incompatibilities that were later corrected).

For the present embodiment, it was also discovered through modeling that GOX activity at concentrations higher than 3-5 mM in the analyte detecting member layer were highly non-linear, and that there was an inhibitory effect on GOX activity at those concentrations. This freed the experimental teams from trying to push the GOX concentration in the analyte detecting member to the solubility limit.

For manufacturing purposes, in some embodiments, the analyte detecting members were designed so that were less than 50 micrometers thin. The model, however, had predicted an optimum balance between response time and cross-sensitivity to sample oxygen for an analyte detecting member of approximately 100 micrometers thickness. It should be understood, of course, that various thicknesses may be used with different devices without deviating from the scope of the invention. So the model was exercised repeatedly to explore the design space; it predicted that if the GOX concentration was changed to 3 mM it would be possible to achieve a similar balance between fast response time, good dynamic range, and low cross sensitivity.

A particularly puzzling phenomenon was discovered when the experimental teams noticed a significant drop-off of glucose signal (an increase in fluorescence lifetime, or more accurately, in hybrid fluorescence phosphorescence lifetime) after only short exposure of the analyte detecting member to the sample. It was discovered through modeling that the analyte detecting member had in fact "used up" all the glucose in the sample solution, and the volume of the sample was subsequently increased.

The discussion of the various optima for the analyte detecting member and their derivation from the model are beyond the scope of this paper and will be reported elsewhere. However, based on multiple model runs and their experimental verification, we have assembled a number of qualitative design rules that should be generally applicable.

The thickness of the whole blood sample layer has no significant effect unless sample layer is very thin (<100 micrometers) and is not shielded from the atmosphere.

In one embodiment, a thinner analyte detecting member will be faster, but oxygen diffusion from the sample will start to be noticeable for analyte detecting members thinner than 100 micrometers. A higher GOX concentration can compensate for this effect. Oxygen or glucose-controlled GOX behavior is not a function of layer thickness but of the ratio between hydrophilic and hydrophobic volume and GOX concentration.

GOX concentration has to be balanced with the hydrophobic phase volume fraction to ensure a good dynamic range as well as a glucose-controlled reaction mechanism.

A ratio of hydrophilic to hydrophobic phase of 80/20 is ideal, but this can be modified as long as GOX concentration is modified as well. Increasing the ratio has three effects that beneficially enhance each other and decrease analyte detecting member response time: (a) faster diffusion of glucose in the hydrophilic phase (there is less impenetrable hydrophobic material in the way), (b) faster removal of oxygen from the hydrophobic phase (because there is less stored oxygen available), and (c) a higher amount of GOX can be used, because there is more hydrophilic phase.

Both layer thickness as well as the ratio of hydrophilic to hydrophobic phase will impact the overall fluorescence intensity that can be obtained from the analyte detecting member.

A low hydrogel polymer fraction (a higher water content) in the hydrogel yields analyte detecting members with faster response.

Catalase contamination in the hydrogel layer converts hydrogen peroxide back into oxygen, thus removing half of the oxygen-consuming effect that the consumption of glucose had on the hydrophobic layer. GOX with low catalase contamination is required.

Droplet sizes below 5 micrometers ensure oxygen diffusion inside the droplets is not a controlling parameter.

While the invention has been described and illustrated with reference to certain particular embodiments thereof, those skilled in the art will appreciate that various adaptations, changes, modifications, substitutions, deletions, or additions of procedures and protocols may be made without departing from the spirit and scope of the invention. For example, with any of the above embodiments, the location of the penetrating member drive device may be varied, relative to the penetrating members or the cartridge. With any of the above embodiments, the penetrating member tips may be uncovered during actuation (i.e. penetrating members do not pierce the penetrating member enclosure or protective foil during launch). With any of the above embodiments, the penetrating members may be a bare penetrating member during launch. With any of the above embodiments, the penetrating members may be bare penetrating members prior to launch as this may allow for significantly tighter densities of penetrating members. In some embodiments, the penetrating members may be bent, curved, textured, shaped, or

otherwise treated at a proximal end or area to facilitate handling by an actuator. The penetrating member may be configured to have a notch or groove to facilitate coupling to a gripper. The notch or groove may be formed along an elongate portion of the penetrating member. With any of the above embodiments, the cavity may be on the  
5 bottom or the top of the cartridge, with the gripper on the other side. In some embodiments, analyte detecting members may be printed on the top, bottom, or side of the cavities. The front end of the cartridge maybe in contact with a user during lancing. The same driver may be used for advancing and retraction of the penetrating member. The penetrating member may have a diameters and length suitable for obtaining the blood  
10 volumes described herein. The penetrating member driver may also be in substantially the same plane as the cartridge. The driver may use a through hole or other opening to engage a proximal end of a penetrating member to actuate the penetrating member along a path into and out of the tissue. The sensory material may be deposited into the via holes. The conductor material may also be deposited into the via holes. The via holes  
15 may be formed by a variety of methods including micro drilling, laser drilling, plasma etching, or the like.

Any of the features described in this application or any reference disclosed herein may be adapted for use with any embodiment of the present invention. For example, the devices of the present invention may also be combined for use with injection penetrating  
20 members or needles as described in commonly assigned, copending U.S. Patent Application Ser. No. 10/127,395 (Attorney Docket No. 38187-2551) filed April 19, 2002. An analyte detecting member to detect the presence of foil may also be included in the lancing apparatus. For example, if a cavity has been used before, the foil or sterility barrier will be punched. The analyte detecting member can detect if the cavity is fresh or  
25 not based on the status of the barrier. It should be understood that in optional embodiments, the sterility barrier may be designed to pierce a sterility barrier of thickness that does not dull a tip of the penetrating member. The lancing apparatus may also use improved drive mechanisms. For example, a solenoid force generator may be improved to try to increase the amount of force the solenoid can generate for a given  
30 current. A solenoid for use with the present invention may have five coils and in the present embodiment the slug is roughly the size of two coils. One change is to increase the thickness of the outer metal shell or windings surround the coils. By increasing the

thickness, the flux will also be increased. The slug may be split; two smaller slugs may also be used and offset by  $\frac{1}{2}$  of a coil pitch. This allows more slugs to be approaching a coil where it could be accelerated. This creates more events where a slug is approaching a coil, creating a more efficient system.

5 In another optional alternative embodiment, a gripper in the inner end of the protective cavity may hold the penetrating member during shipment and after use, eliminating the feature of using the foil, protective end, or other part to retain the used penetrating member. Some other advantages of the disclosed embodiments and features of additional embodiments include: same mechanism for transferring the used penetrating  
10 members to a storage area; a high number of penetrating members such as 25, 50, 75, 100, 500, or more penetrating members may be put on a disk or cartridge; molded body about a lancet becomes unnecessary; manufacturing of multiple penetrating member devices is simplified through the use of cartridges; handling is possible of bare rods metal wires, without any additional structural features, to actuate them into tissue; maintaining  
15 extreme (better than 50 micron -lateral- and better than 20 micron vertical) precision in guiding; and storage system for new and used penetrating members, with individual cavities/slots is provided. The housing of the lancing device may also be sized to be ergonomically pleasing. In one embodiment, the device has a width of about 56 mm, a length of about 105 mm and a thickness of about 15 mm. Additionally, some  
20 embodiments of the present invention may be used with non-electrical force generators or drive mechanism. For example, the punch device and methods for releasing the penetrating members from sterile enclosures could be adapted for use with spring based launchers. The gripper using a frictional coupling may also be adapted for use with other drive technologies.

25 Still further optional features may be included with the present invention. For example, with any of the above embodiments, the location of the penetrating member drive device may be varied, relative to the penetrating members or the cartridge. With any of the above embodiments, the penetrating member tips may be uncovered during actuation (i.e. penetrating members do not pierce the penetrating member enclosure or  
30 protective foil during launch). The penetrating members may be a bare penetrating member during launch. In some embodiments, the penetrating member may be a patent needle. The same driver may be used for advancing and retraction of the penetrating

member. Different analyte detecting members detecting different ranges of glucose concentration, different analytes, or the like may be combined for use with each penetrating member. Non-potentiometric measurement techniques may also be used for analyte detection. For example, direct electron transfer of glucose oxidase molecules adsorbed onto carbon nanotube powder microelectrode may be used to measure glucose levels. In some embodiments, the analyte detecting members may be formed to flush with the cartridge so that a "well" is not formed. In some other embodiments, the analyte detecting members may be formed to be substantially flush (within 200 microns or 100 microns) with the cartridge surfaces. In all methods, nanoscopic wire growth can be carried out via chemical vapor deposition (CVD). In all of the embodiments of the invention, preferred nanoscopic wires may be nanotubes. Any method useful for depositing a glucose oxidase or other analyte detection material on a nanowire or nanotube may be used with the present invention. Additionally, for some embodiments, any of the cartridge shown above may be configured without any of the penetrating members, so that the cartridge is simply an analyte detecting device. Still further, the indexing of the cartridge may be such that adjacent cavities may not necessarily be used serially or sequentially. As a nonlimiting example, every second cavity may be used sequentially, which means that the cartridge will go through two rotations before every or substantially all of the cavities are used. As another nonlimiting example, a cavity that is 3 cavities away, 4 cavities away, or N cavities away may be the next one used. This may allow for greater separation between cavities containing penetrating members that were just used and a fresh penetrating member to be used next. It should be understood that the spring-based drivers shown in the present invention may be adapted for use with any of the cartridges shown herein such as, but not limited to, those shown in Figures 61 and 62. These spring-based drivers may also be paired with gripper blocks that are configured to penetrate into cartridges that fully seal penetrating member therein, in order to engage those penetrating members. The start and end positions of the penetrating members may also be the same. The penetrating members may be parked in a holder before actuation, and in some embodiments, into a holder after actuation (as seen in cartridge 500 or any other cartridge herein). Embodiments of the present invention may also include guides which provide lateral constraints and/or vertical constraints about penetrating member. These constraints may be positioned about the shaft portions of the penetrating member. For

any of the embodiments herein, they may be configured to provide the various velocity profiles described. The analyte detecting members may use volumes of less than 1 microliter, less than 500nl, 400nl, 300nl, 200nl, 100nl, 75nl, 60nl, 50nl, 40nl, 30nl, 20nl, 10nl, or less of body fluid. In some embodiments, the chamber that holds the body fluid over the electrodes is less than 1 microliter, less than 500nl, 400nl, 300nl, 200nl, 100nl, 75nl, 60nl, 50nl, 40nl, 30nl, 20nl, 10nl, or less in volume. In still other embodiments, the volume of the chamber over the electrodes is less than 1 microliter, less than 500nl, 400nl, 300nl, 200nl, 100nl, 75nl, 60nl, 50nl, 40nl, 30nl, 20nl, 10nl, or less. Any of the features set forth in the present description may be combined with any other feature of the embodiments set forth above.

The publications discussed or cited herein are provided solely for their disclosure prior to the filing date of the present application. The following applications are incorporated herein by reference for all purposes: Ser. Nos. 60/507,317, 60/507,852, 60/507,845, 60/507,690, and 60/507,688. Nothing herein is to be construed as an admission that the present invention is not entitled to antedate such publication by virtue of prior invention. Further, the dates of publication provided may be different from the actual publication dates which may need to be independently confirmed. All publications and applications mentioned herein are incorporated herein by reference to disclose and describe the structures and/or methods in connection with which the publications are cited.

Expected variations or differences in the results are contemplated in accordance with the objects and practices of the present invention. It is intended, therefore, that the invention be defined by the scope of the claims which follow and that such claims be interpreted as broadly as is reasonable.



WHAT IS CLAIMED IS:

- 1           1.     A body fluid sampling device comprising:  
2           a single cartridge;  
3           a penetrating member coupled to said single cartridge; and  
4           an analyte detecting members.
- 1           2.     A method of controlling fluid flow, the method comprising:  
2           (a)    providing a cartridge configured to slidably hold a plurality of  
3           penetrating members and to have a plurality of analyte detecting members; and  
4           (b)    using surface texturing on the cartridge to form texturing to direct  
5           fluid into a desired area on the cartridge.
- 1           3.     The method of claim 2 wherein said texturing is formed  
2           chemically.
- 1           4.     The method of claim 2 wherein the surface texturing guides the  
2           fluid to one of said analyte detecting members.
- 1           5.     A body fluid sampling device comprising:  
2           a single cartridge;  
3           a plurality of penetrating members coupled to said single cartridge and  
4           operatively couplable to a penetrating member driver, said penetrating members movable  
5           to extend radially outward from the cartridge to penetrate tissue;  
6           a plurality of analyte detecting members coupled to said single cartridge,  
7           wherein at least one of said analyte detecting members positioned on the cartridge to  
8           receive body fluid from a wound in the tissue created by the penetrating member when  
9           the cartridge is in an operative position; and  
10          a texture structure on said cartridge positioned to guide fluid generated by  
11          said tissue towards one of the analyte detecting members.
- 1           6.     A body fluid sampling device comprising:  
2           a single cartridge;

3 a plurality of penetrating members coupled to said single cartridge and  
4 operatively couplable to the penetrating member driver, said penetrating members  
5 movable to extend radially outward from the cartridge to penetrate tissue;

6 a plurality of analyte detecting members coupled to said single cartridge,  
7 wherein at least one of said analyte detecting members positioned on the cartridge to  
8 receive body fluid from a wound in the tissue created by the penetrating member when  
9 the cartridge is in an operative position; and

10 a plurality of mesh structures positioned to draw fluid generated by said  
11 tissue towards one of the analyte detecting members.

1 7. The device of claim 6 further comprising a ring around the  
2 cartridge wherein said analyte detecting members are mounted on said ring, along with  
3 said mesh.

1 8. The device of claim 6 further comprising a ring around the  
2 cartridge wherein said analyte detecting members are coupled to said cartridge through  
3 said ring.

1 9. The device of claim 6 further comprising a plurality of electrodes  
2 coupled to said analyte detecting member.

1 10. The device of claim 6 wherein the mesh is a gradient mesh.

1 11. A body fluid sampling device comprising:  
2 a support structure;  
3 a sensory material on a first side of said support structure;  
4 a conductor material coupled to the sensory material; and  
5 a commutator positioned to engage said conductor material to obtain  
6 analyte measurements.

1 12. The device of claim 11 further comprising a radial cartridge, said  
2 support structure coupled to said radial cartridge.

1 13. The device of claim 11 further comprising a plurality of electrodes  
2 each having said sensory material.

1 14. A penetrating member actuator comprising:

2 a support structure;  
3 a first electrode;  
4 a second electrode;  
5 an elastomeric material between said electrodes, wherein said material  
6 elongates upon activation of the electrodes, causing a penetrating member to move.

1 15. The device of claim 14 further comprising a radial cartridge, said  
2 material having a gripper positioned to engage penetrating members on said radial  
3 cartridge.

1 16. The device of claim 14 further comprising a coupler in contact with  
2 the material for coupling the penetrating member to the material.

1 17. A method for designing an analyte detecting member, the method  
2 comprising:

- 3 (a) mathematically replicating the significant physical and chemical  
4 processes taking place in the analyte detecting member and sample; and  
5 (b) dividing assay time into small time steps and the analyte detecting  
6 member into small control volumes, wherein during each time step (and in each control  
7 volume), the model simultaneously solves a specie conservation equation for each  
8 important constituent: oxygen, glucose, glucose oxidase, catalase, and hydrogen peroxide.

1 18. The method of claim 17 wherein each conservation equation  
2 includes an accumulation term, a diffusion term, and a production/destruction term  
3 wherein the latter relies on a production rate calculated either as a Michaelis-Menton  
4 reaction (catalase) or Ping-Pong Bi-Bi reaction (glucose oxidase).

1 19. The method of claim 17 wherein tracking the diffusion of each  
2 important chemical component of the emulsion and sample, the chemical reactions  
3 between them, and the resulting signal from oxygen depletion.

1 20. The method of claim 17 wherein treating the emulsion as a  
2 continuum with properties based on volume-fraction averages of the properties of the  
3 hydrophobic and hydrophilic phases.

1

1/24

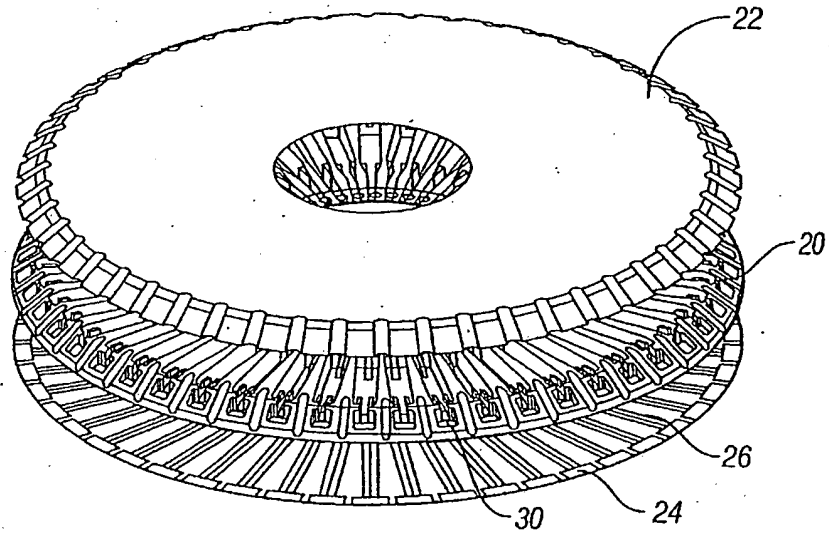

FIG. 1

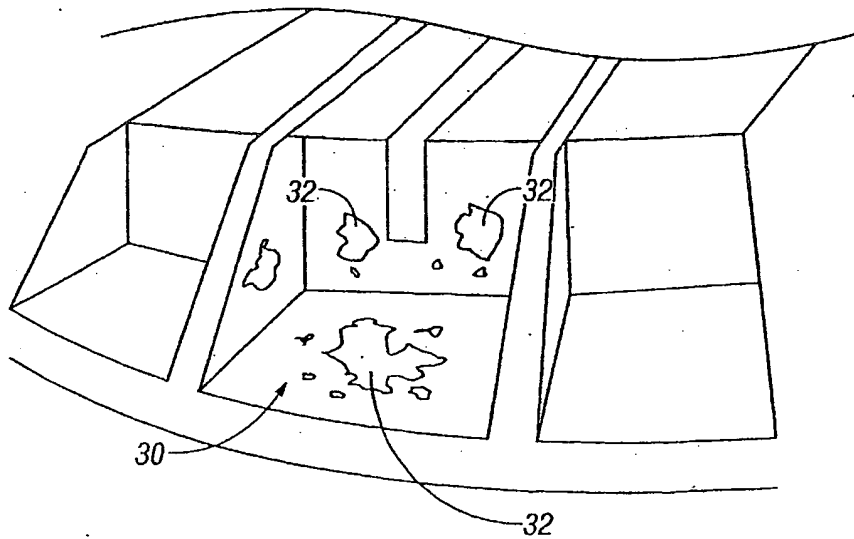
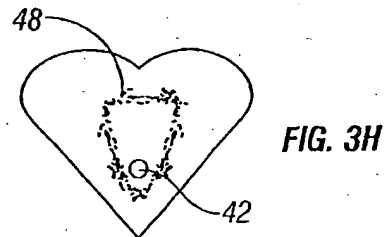
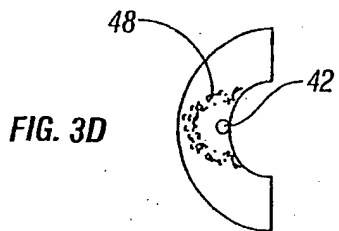
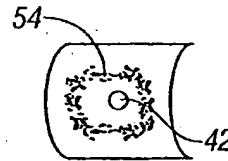
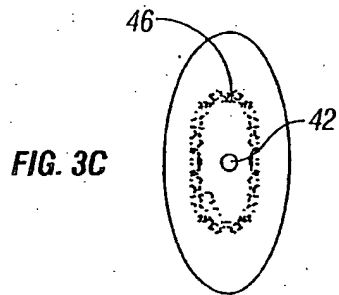
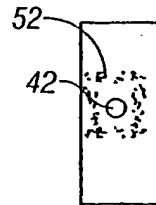
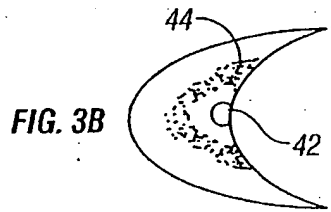
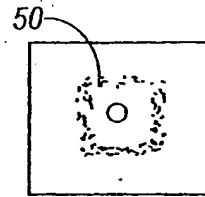
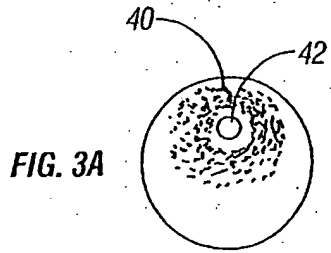

FIG. 2

SUBSTITUTE SHEET (RULE 26)



3/24

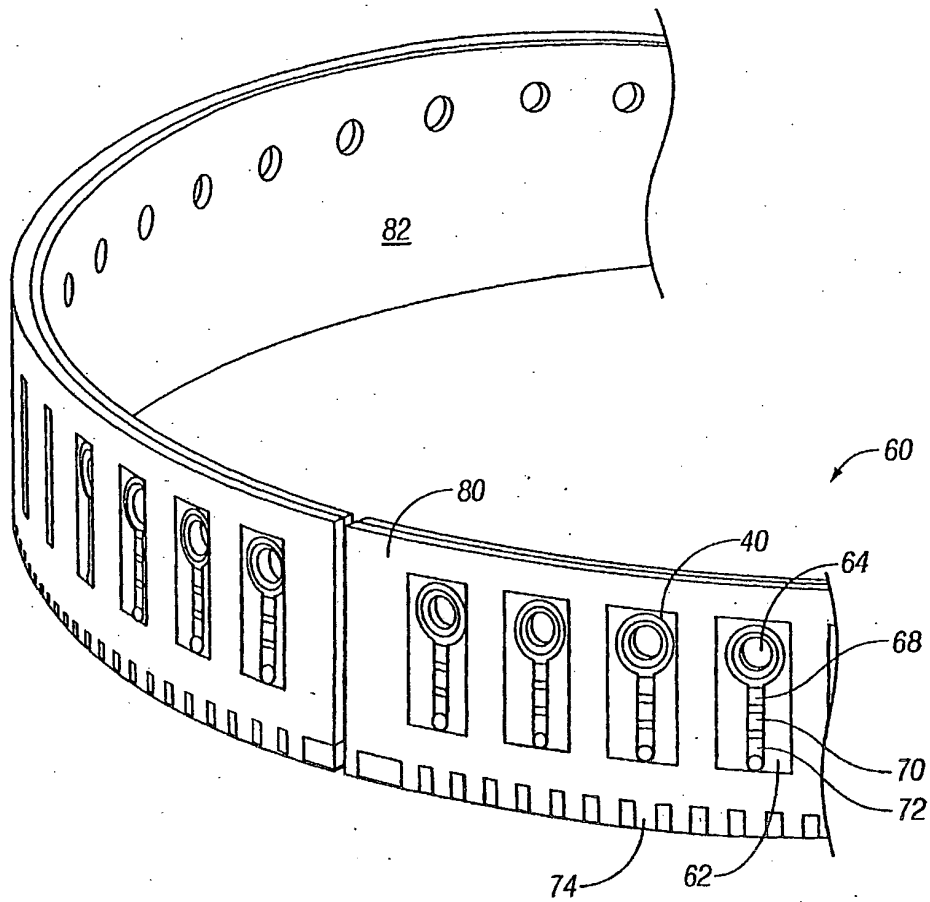

FIG. 4

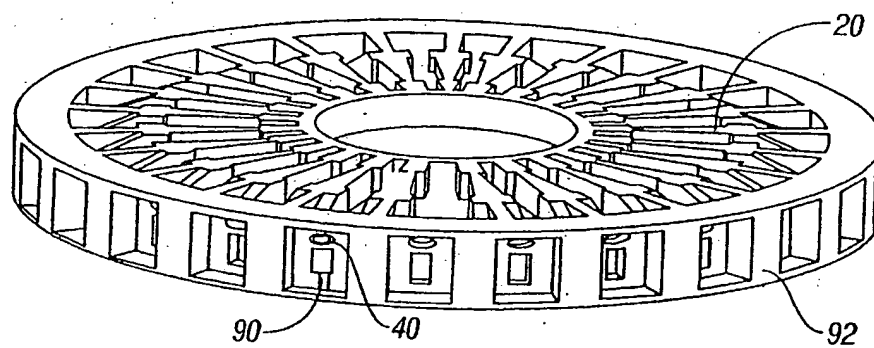

FIG. 5

5/24

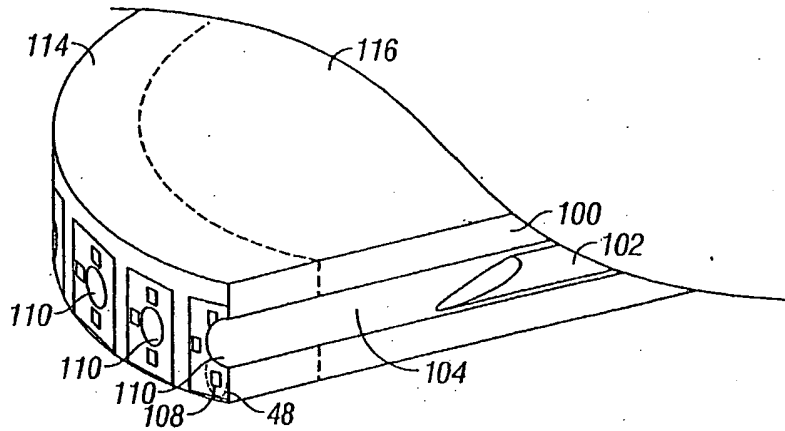

FIG. 6

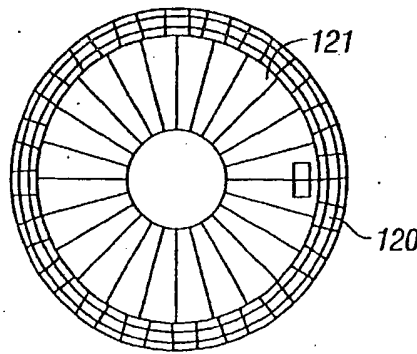

FIG. 7



6/24

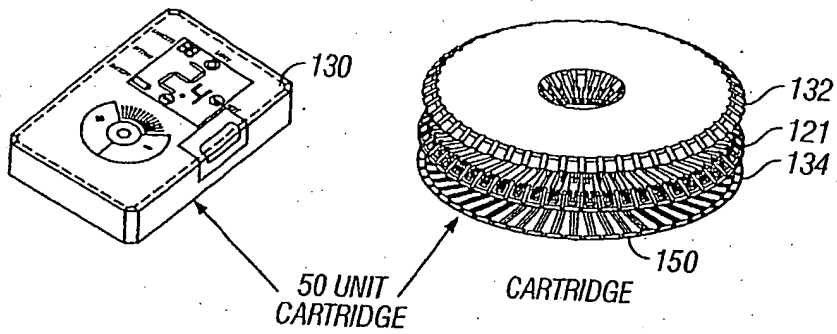

FIG. 8

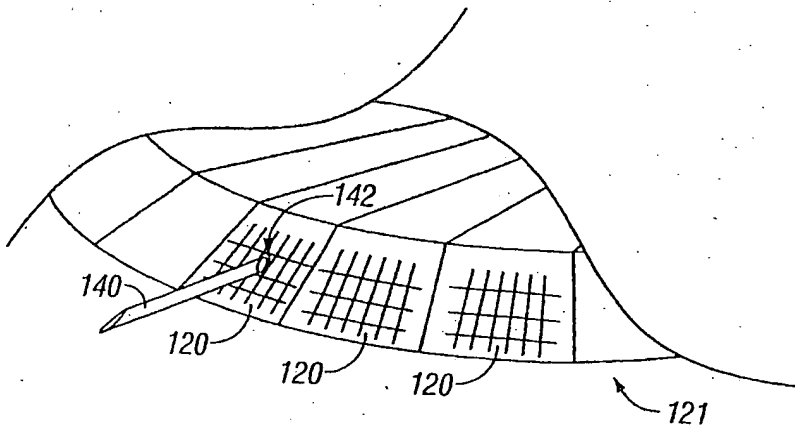

FIG. 9

7/24

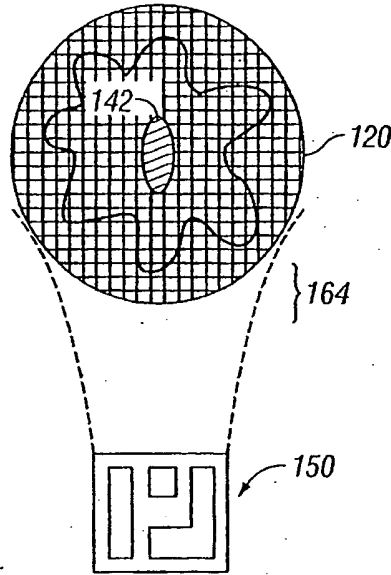

FIG. 10

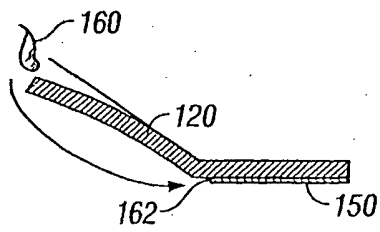

FIG. 11

8/24

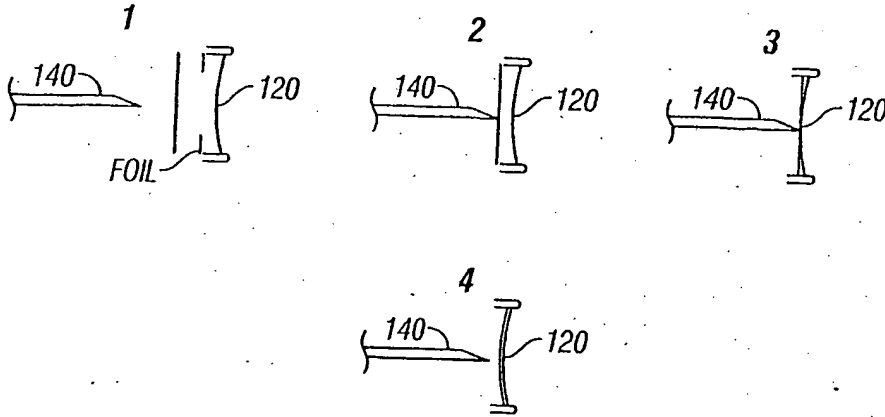

FIG. 12

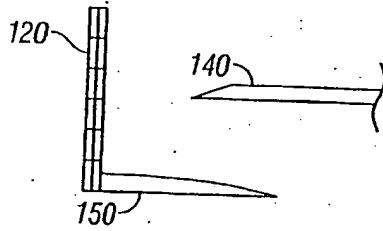

FIG. 13

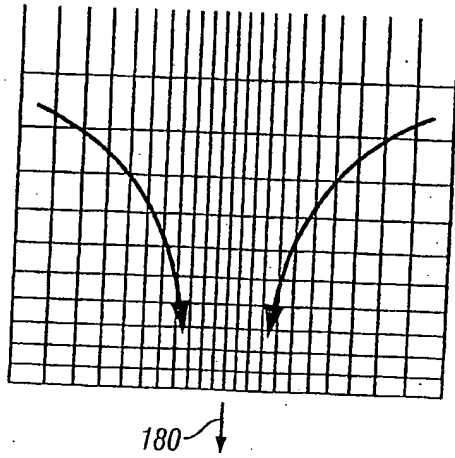

FIG. 14

SUBSTITUTE SHEET (RULE 26)

9/24

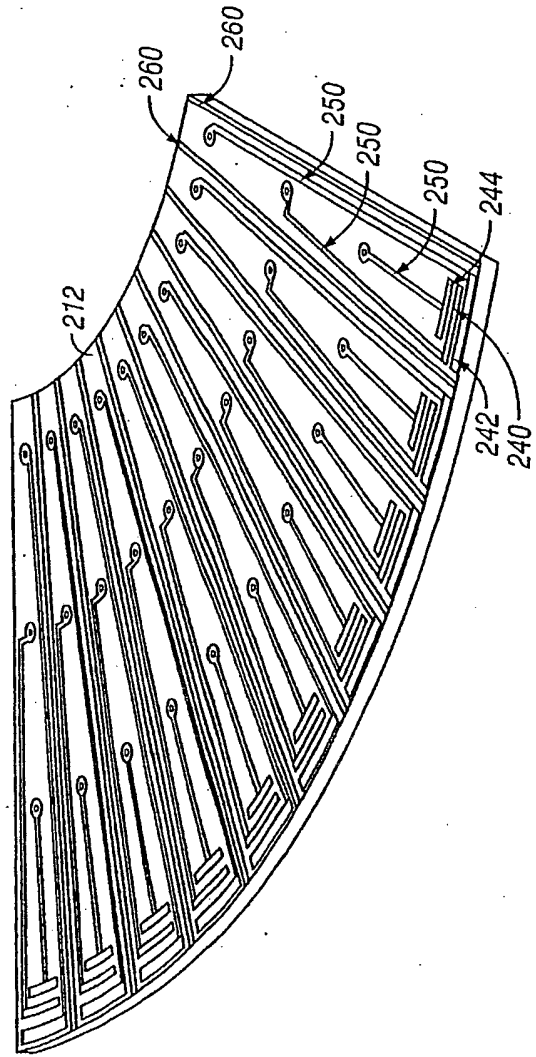

FIG. 15

10/24

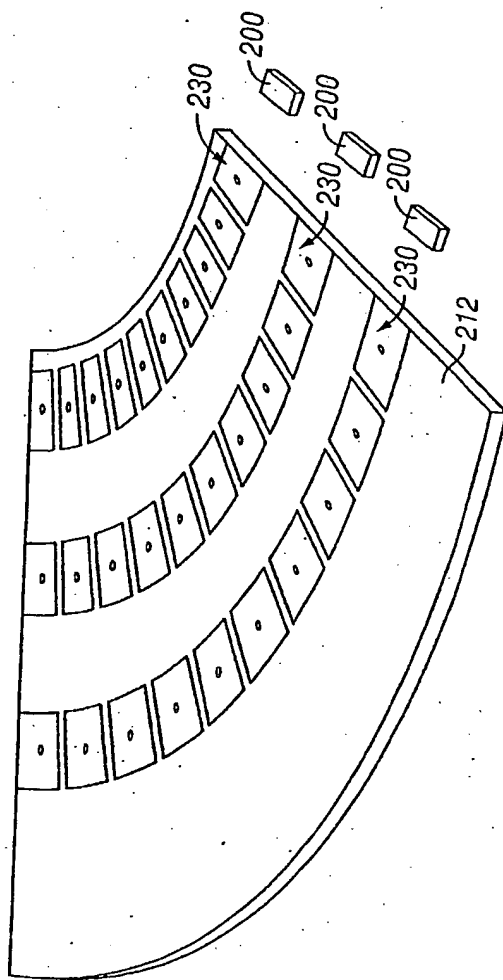

FIG. 16

11/24

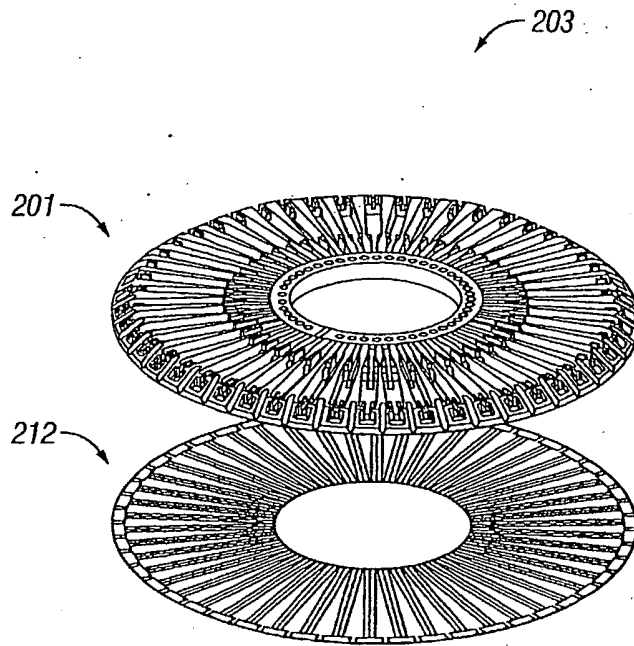

FIG. 17

12/24

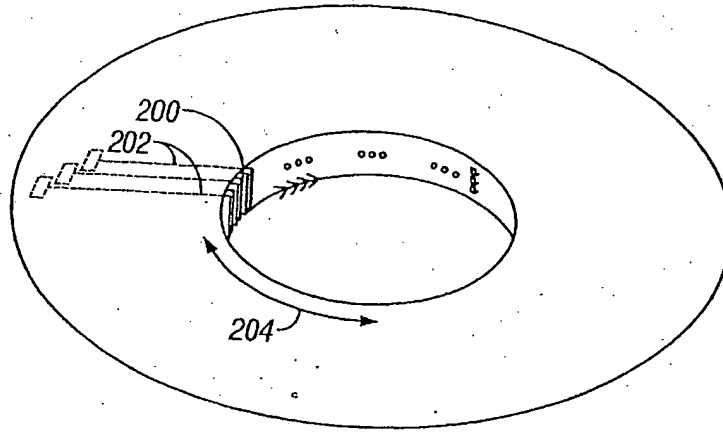

FIG. 18

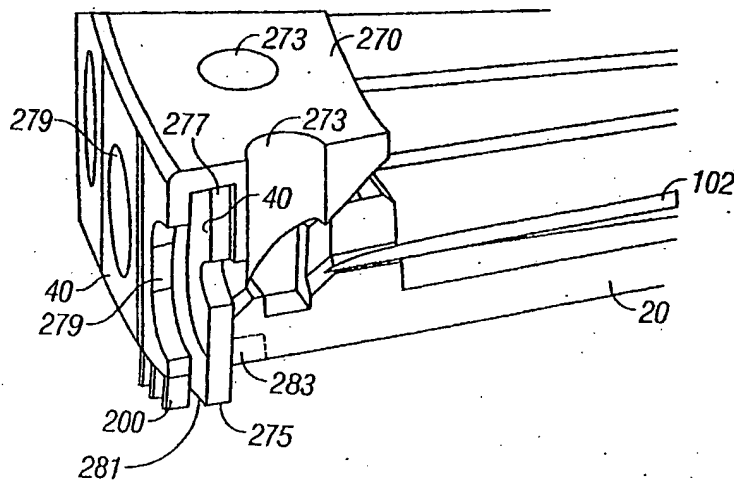

FIG. 19

13/24

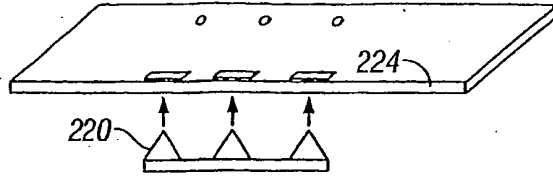

FIG. 20

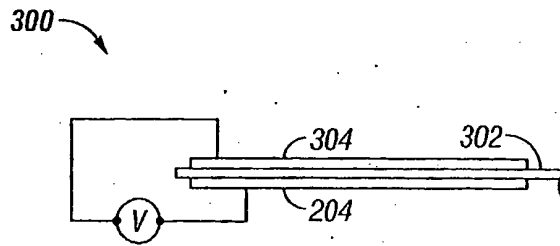

FIG. 21

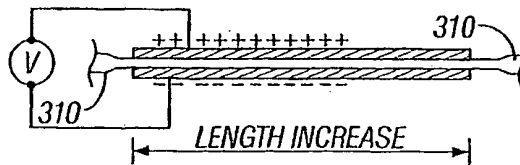

FIG. 22



14/24

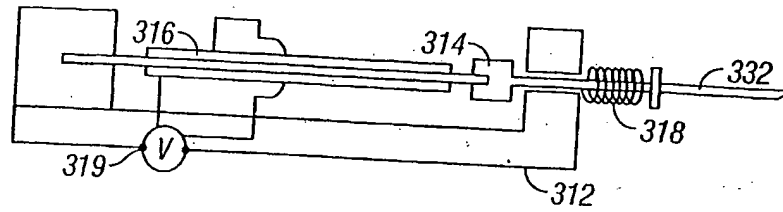

FIG. 23A

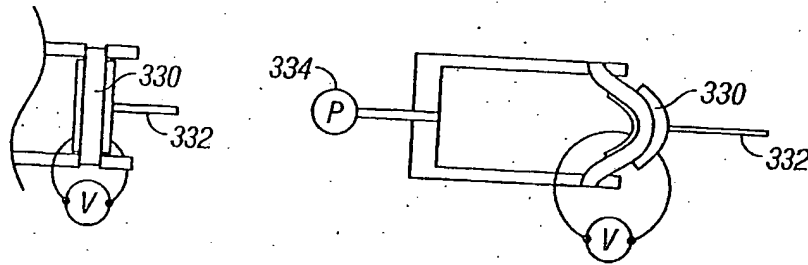

FIG. 23B

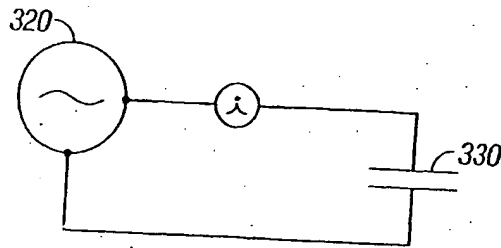

FIG. 24

15/24

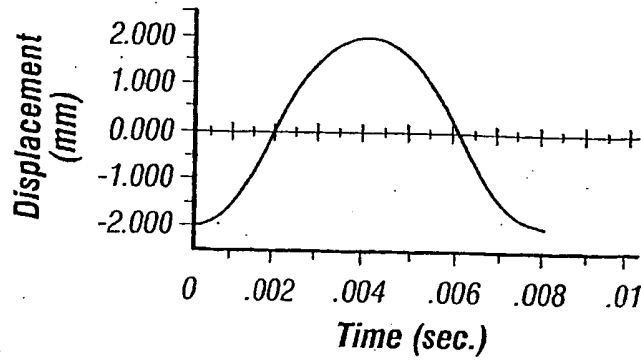

FIG. 25A

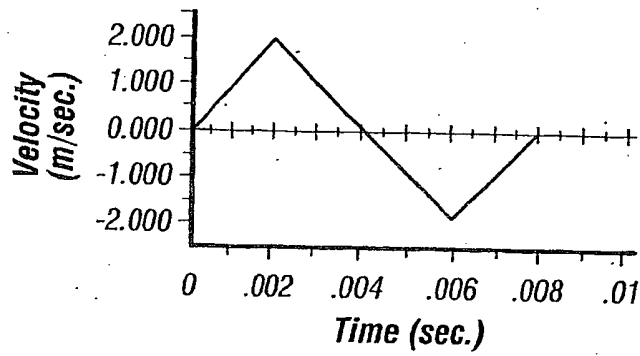

FIG. 25B

16/24

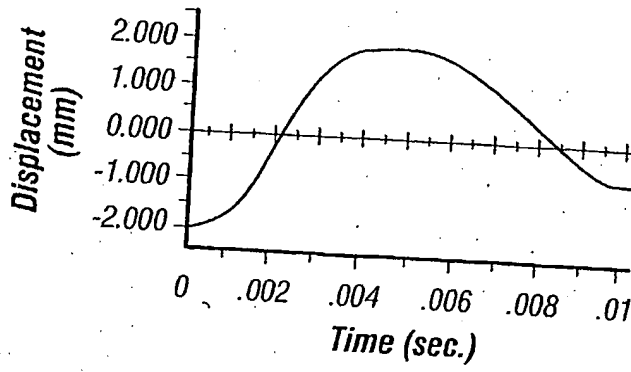

FIG. 25C

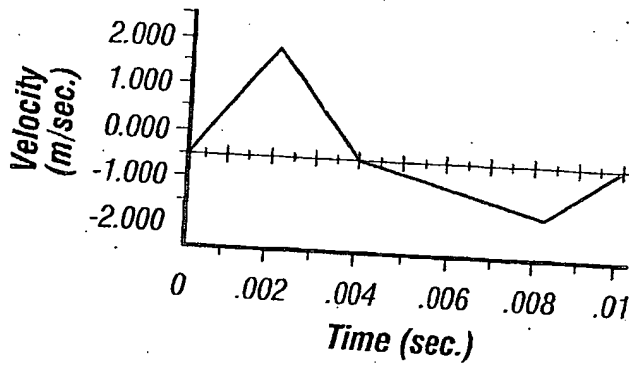

FIG. 25D

17/24

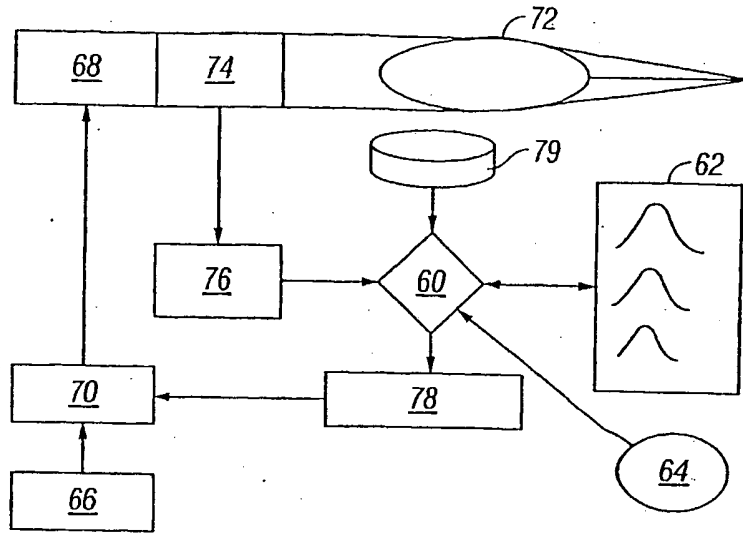

FIG. 26

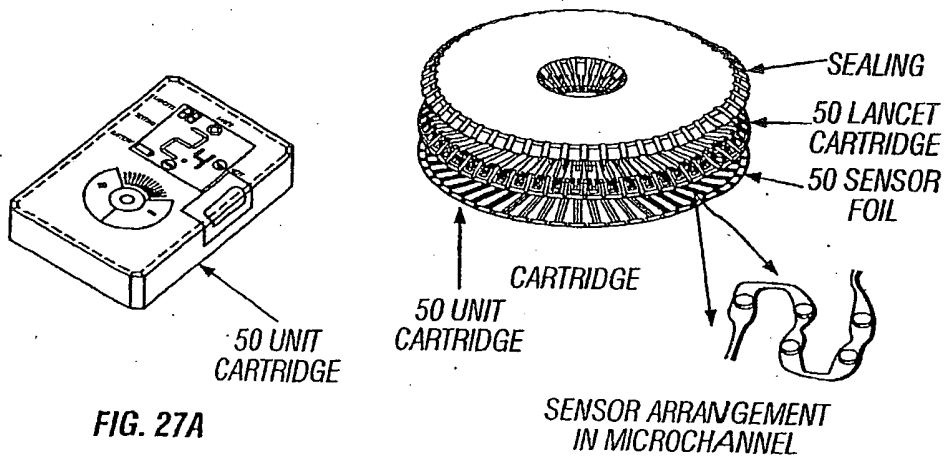

FIG. 27A

FIG. 27B

18/24

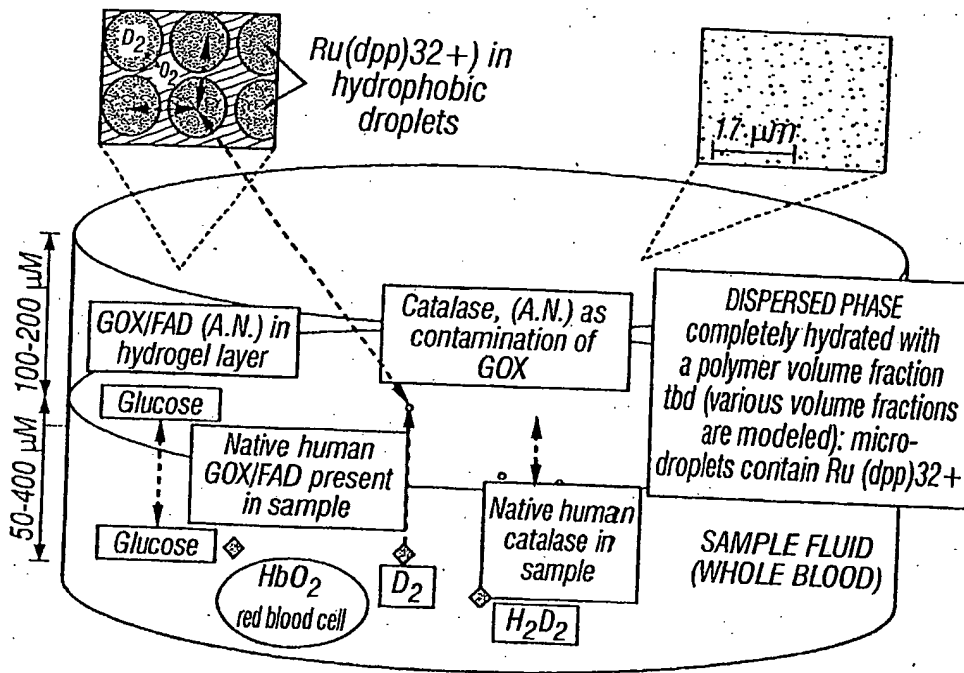

FIG. 28

19/24

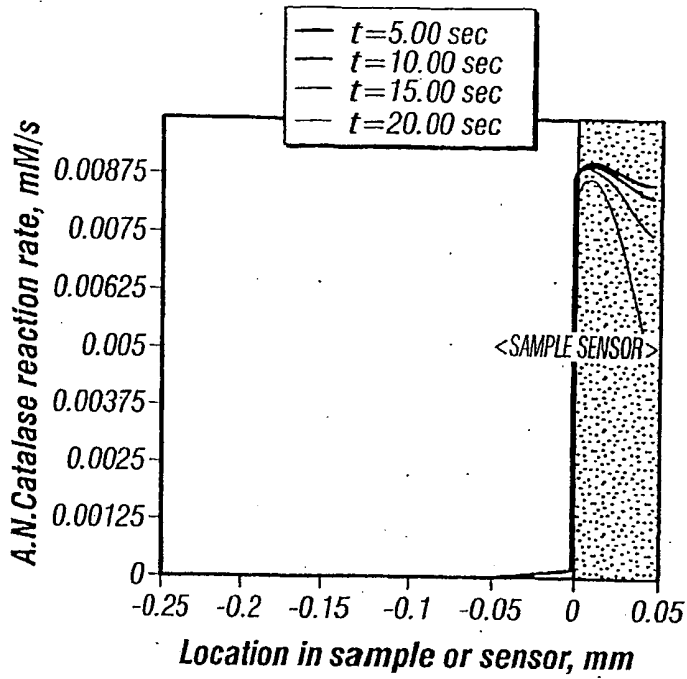

FIG. 29a

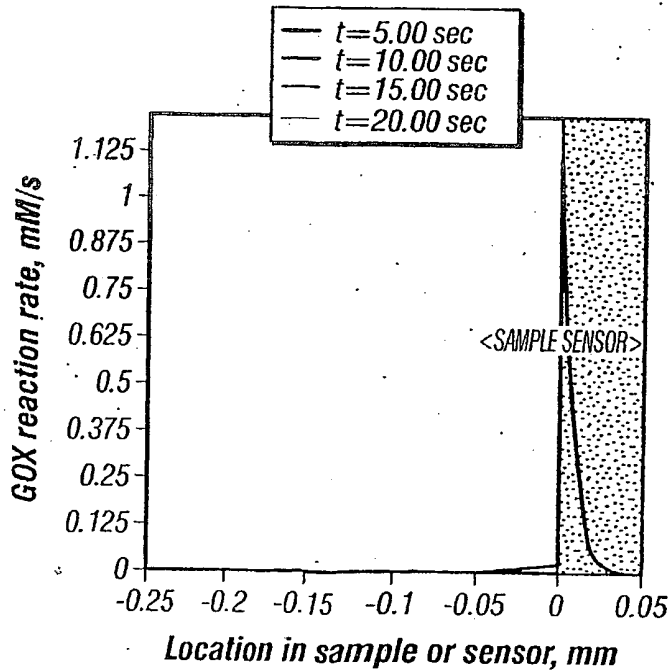

FIG. 29b

SUBSTITUTE SHEET (RULE 26)

20/24

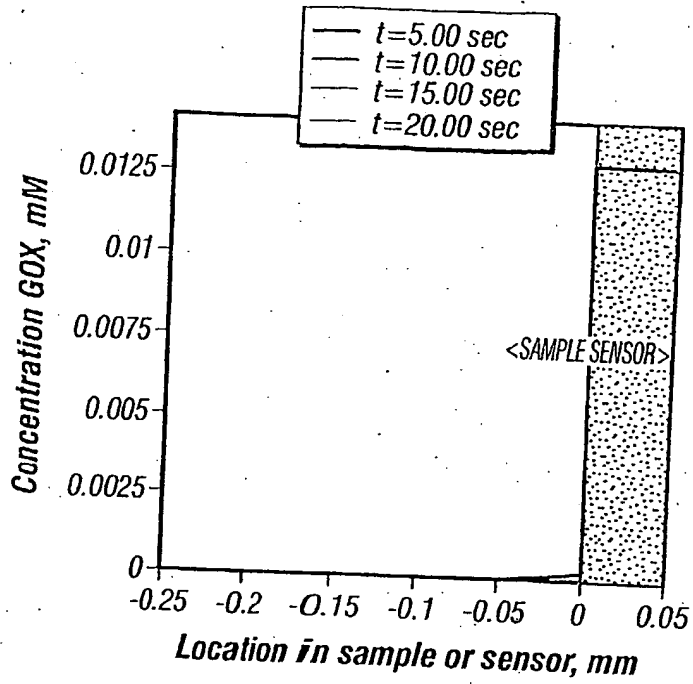

FIG. 30a

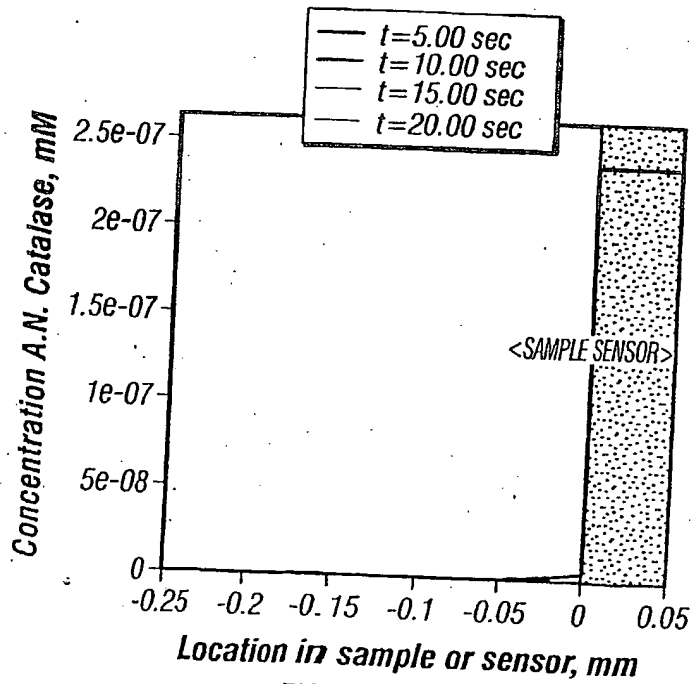

FIG. 30b

21/24

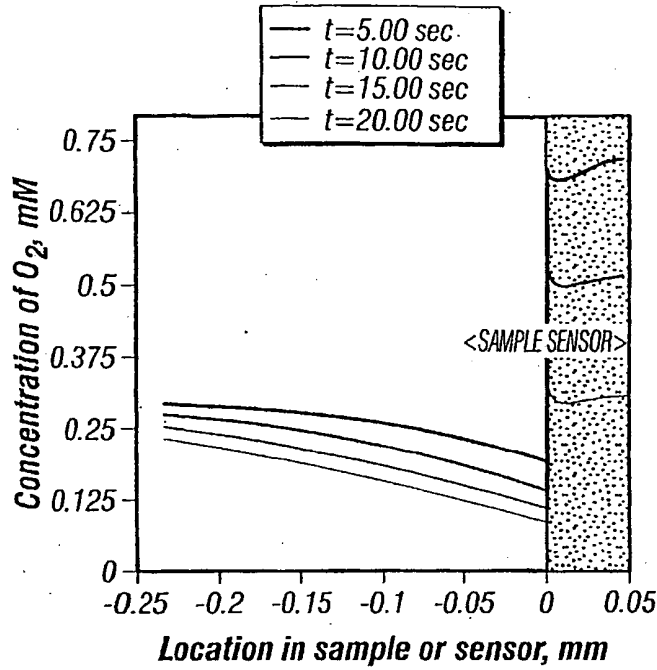

FIG. 31a

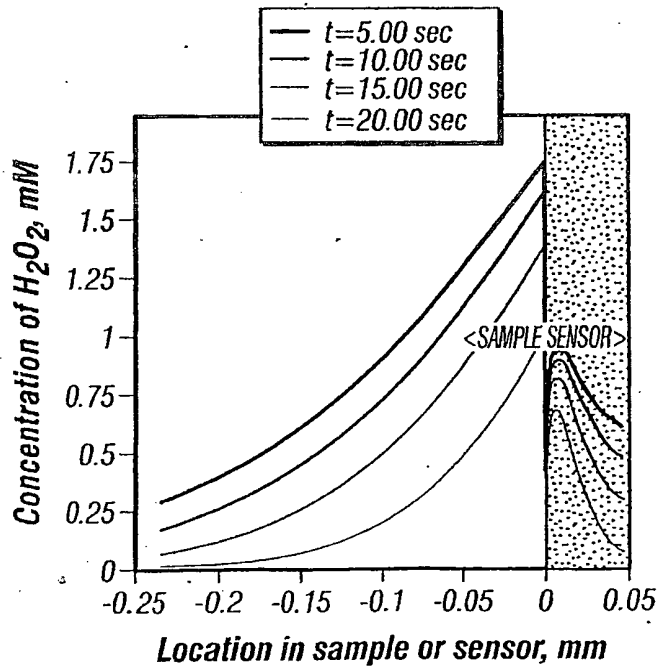

FIG. 31b

SUBSTITUTE SHEET (RULE 26)



22/24

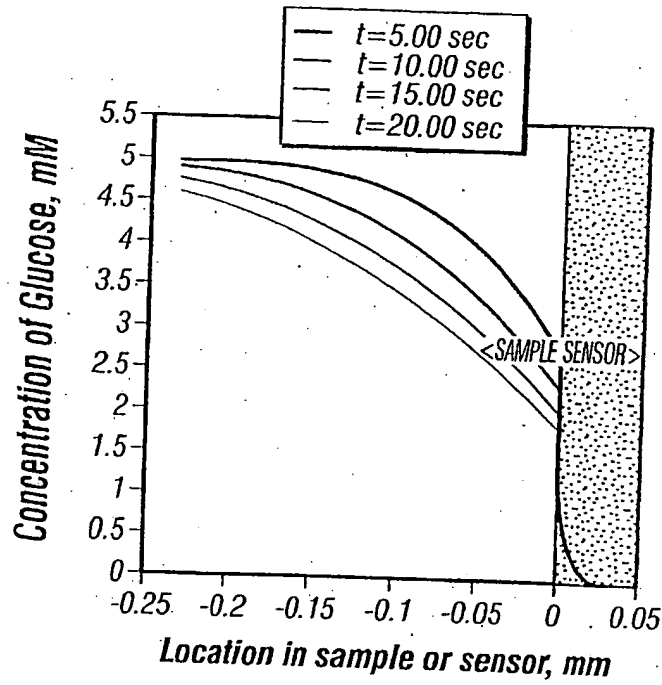

FIG. 31c

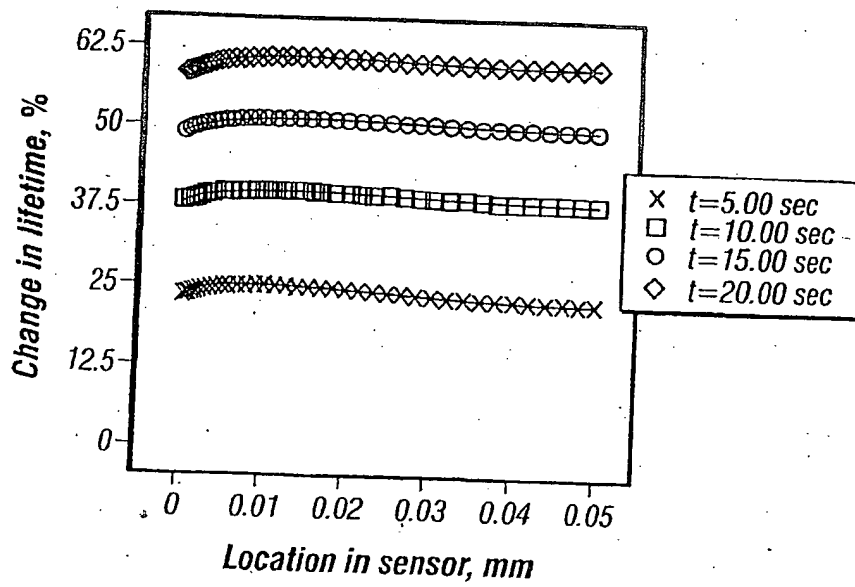

FIG. 32

23/24

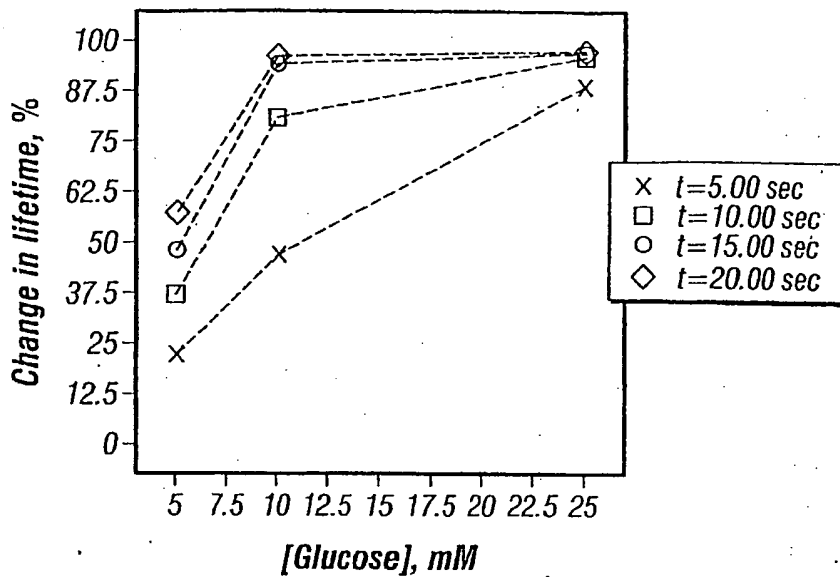

FIG. 33a

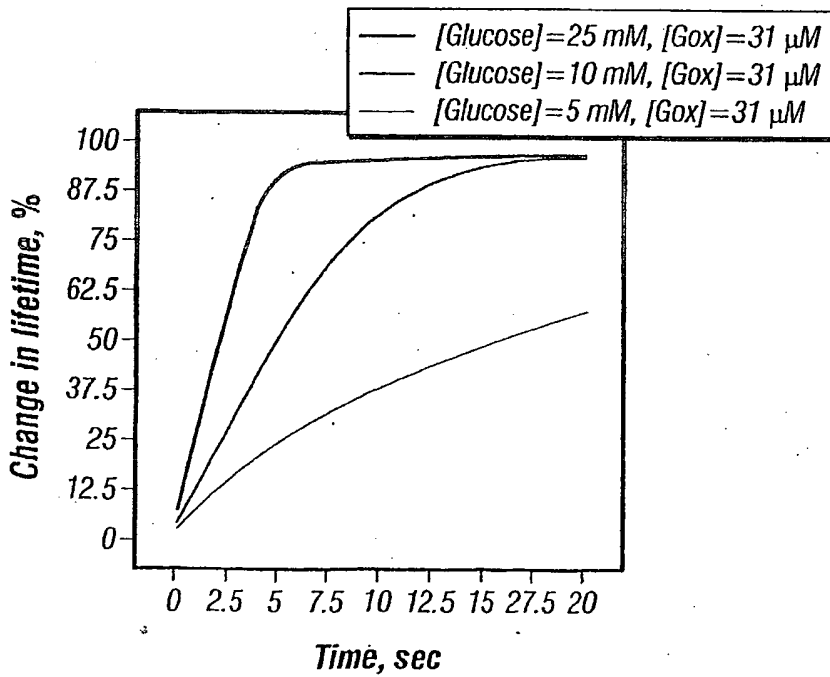

FIG. 33b

24/24

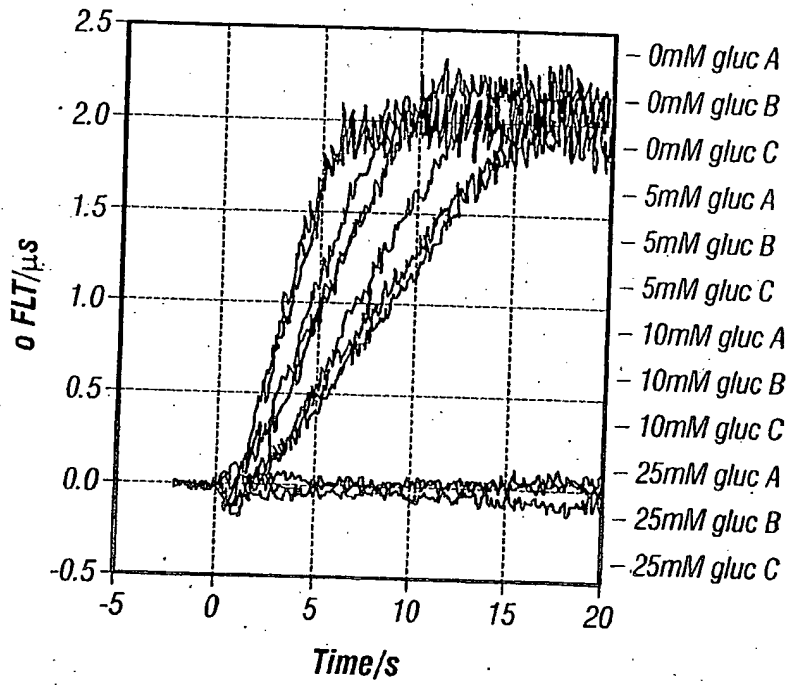

FIG. 34

**BLANK PAGE**